

User manual



60888953_00

JX4-CNT8 Counter Module

This document has been compiled by Bucher Automation AG with due diligence based on the state of the art as known to them. Any revisions and technical advancements of our products are not automatically made available in a revised document.

The Bucher Automation AG shall not be liable for any errors either in form or content, or for any missing updates, as well as for any damage or detriment resulting from such failure.



Bucher Automation AG

Thomas-Alva-Edison-Ring 10
71672 Marbach/Neckar, Germany
T +49 7141 2550-0
info@bucherautomation.com

Technical support

T +49 7141 2550-444
support@bucherautomation.com

Sales

T +49 7141 2550-663
sales@bucherautomation.com

www.bucherautomation.com

Translation of the german original User Manual

Revision	1.00
Date of issue	2/20/2026

Table of Contents

1	Introduction.....	5
1.1	Information on this document	5
1.2	Typographical conventions.....	5
2	Safety.....	6
2.1	General.....	6
2.2	Purpose	6
2.2.1	Intended use.....	6
2.2.2	Non-intended use	6
2.3	Warnings used in this document	7
3	Product description.....	8
3.1	System overview	8
3.2	Design	9
3.3	Product features	9
3.4	Status indication	10
3.4.1	Lighting patterns of the LEDs	10
3.4.2	LED status indicators.....	10
3.5	Nameplate	11
3.6	Scope of delivery	11
4	Technical specifications	12
4.1	Dimensions.....	12
4.2	Mechanical specifications.....	13
4.3	Electrical properties	13
4.4	Environmental conditions	14
4.5	EMC Values.....	15
5	Mechanical installation	16
5.1	Order and arrangement.....	16
5.2	Installing the device on the DIN rail	16
5.3	Assembling the expansion module.....	18
5.4	Installing the end cover and retainers.....	19
5.5	Removing the device from the DIN rail.....	20
6	Electrical connection	23
6.1	Improving EMC Noise Immunity	23
6.2	Wiring	24
6.3	Block diagrams	24
6.3.1	JX4-CNT8.....	24

7	Identification and configuration	25
7.1	Incorporating an EtherCAT® device as 3rd-party.....	25
7.2	Adding expansion modules	25
8	Programming	27
8.1	Incorporating the files in the project.....	27
8.2	Configuring the objects and modules	27
8.2.1	Definition of configuration parameters	27
8.2.2	Configuration of the filter level	27
8.3	Process data.....	28
8.3.1	Input data.....	28
8.3.2	Output data.....	29
8.4	Declare inputs and outputs.....	29
9	Maintenance	32
9.1	Repairs	32
9.2	Storage and Shipment.....	32
9.3	Return and Disposal	32
10	Service	34
10.1	Technical support	34
11	Spare parts and accessories	35

1 Introduction

1.1 Information on this document

This document forms an integral part of the product and must be read and understood prior to using the device. It contains important and safety-related information for the proper use of the product as intended.

Target Groups

This document is intended for specialists with appropriate qualifications.

Only competent and trained personnel are allowed to put this device into operation.

During the whole product life cycle, safe handling and operation of the device must be ensured. In the case of missing or inadequate technical knowledge or knowledge of this document any liability is excluded.

Availability of Information

Make sure this document is kept at the ready in the vicinity of the product throughout its service life.

For information on new revisions of this document, visit the download area on our website. This document is not subject to any updating service.

[Start | www.bucherautomation.com](http://www.bucherautomation.com)

For further information refer to the following information products:

- Online help for the JetSym software
Functions of software products with application examples
- Application-oriented manuals
Product-independent documentation
- Version updates
Information about changes to the software products and operating system of your device

Info

Further information

For further information on the noise immunity of a system, please refer to the Application Note 016 *EMC-Compatible Installation of the Electric Cabinet* available for download on www.bucherautomation.com.

Info

EtherCAT®

EtherCAT® is a registered trademark and patented technology, licensed by Beckhoff Automation GmbH, Germany.

1.2 Typographical conventions

This manual uses different typographical effects to support you in finding and classifying information. Below, there is an example of a step-by-step instruction:

- ✓ This symbol indicates requirements which have to be met before executing the following action.
- ▶ This sign or a numbering at the beginning of a paragraph marks an action instruction that must be executed by the user. Execute the instructions one after the other.
- ⇒ The target after a list of instructions indicates reactions to, or results of these actions.

Info

Further information and practical tips

In the info box you will find helpful information and practical tips about your product.

2 Safety

2.1 General

The product corresponds to the current state of science and technology when placed on the market. In addition to this user manual, the laws, regulations and directives of the country of operation or the EU apply to the operation of the product. The operator is responsible for compliance with the relevant accident prevention regulations and generally recognized safety rules.

2.2 Purpose

2.2.1 Intended use

The JX4 system works with a combination of bus nodes and I/O modules.

Operate the device only in accordance with the intended conditions of use and within the limits set forth in the technical specifications.

Intended use of the product includes its operation in accordance with this manual.

SELV

The operating voltage of this device is classified as Safety Extra Low Voltage and is, therefore, not subject to the EU Low Voltage Directive. The device may only be operated from a SELV source.

2.2.2 Non-intended use

Do not use the device in technical systems for which a high level of failure safety is specified.

Machinery Directive

This device is not a safety-related part as per Machinery Directive 2006/42/EC and must, therefore, not be used for safety-relevant applications.

2.3 Warnings used in this document

DANGER



High risk

Indicates an imminently hazardous situation which, if not avoided, will result in death or serious injury.

WARNING



Medium risk

Indicates a potentially hazardous situation which, if not avoided, could result in death or serious injury.

CAUTION



Low risk

Indicates a hazardous situation which, if not avoided, could result in minor or moderate injury.

NOTICE



Material damage

Indicates a situation which, if not avoided, could result in malfunctions or material damage.

3 Product description

The JX4-CNT8 module from the JX4 family is a pulse counter module.

3.1 System overview



Fig. 1: System overview

3.2 Design

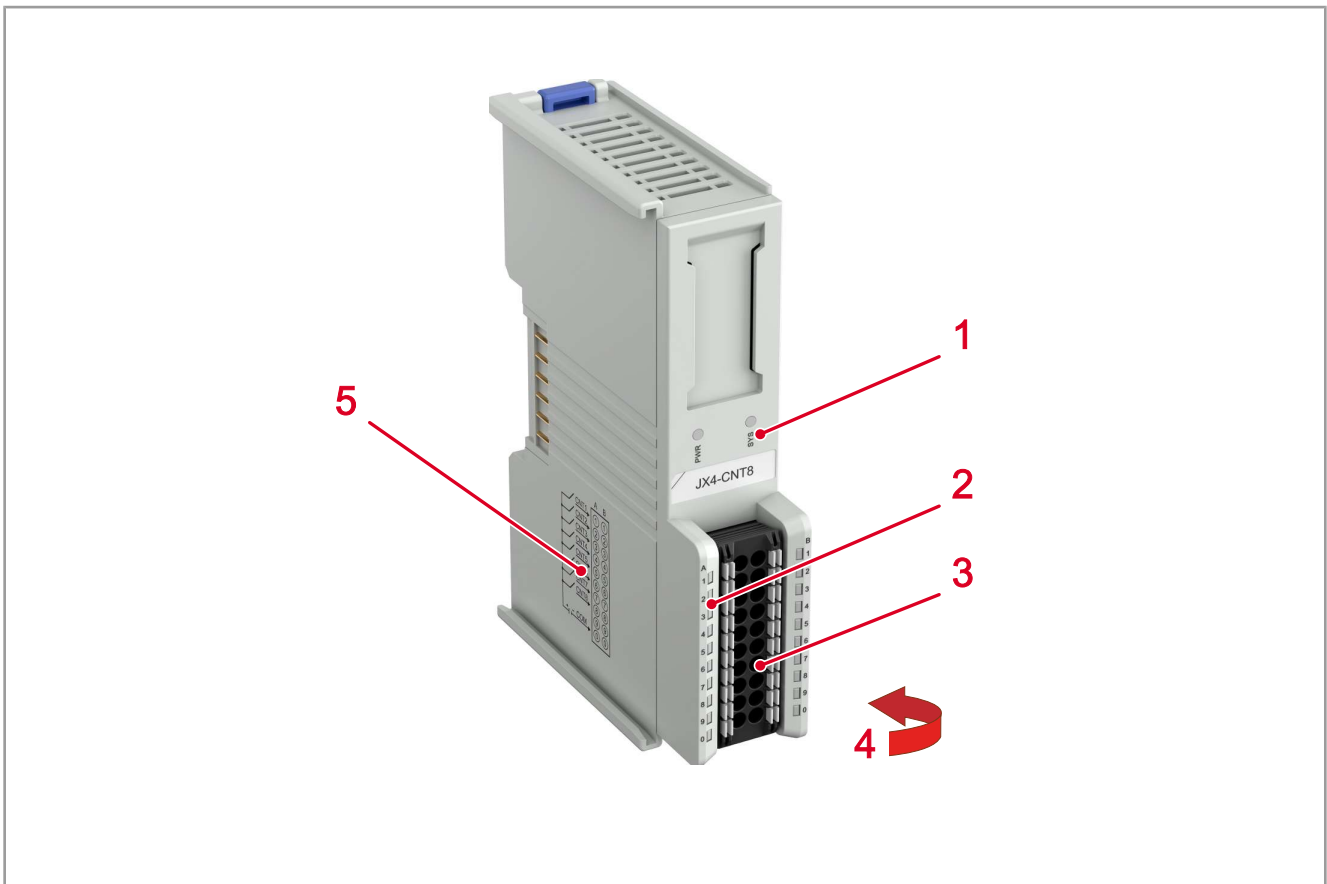

Fig. 2: Design

1	System display
2	Channel display
3	Channels for pulse counting
4	Nameplate (on the right-hand side of the housing)
5	Pinout

3.3 Product features

- Eight-channel, independent pulse counting
- Pulse counting channels can be deleted independently of each other
- 100 kHz pulse counting frequency
- Input filtering selectable in 16 levels
- LEDs for monitoring supply voltage and communication

3.4 Status indication

Status indication LEDs show the communication status of the device as well as the status of the power supply.

Color and status of the LEDs facilitate diagnosing various states.

3.4.1 Lighting patterns of the LEDs

Parameter	Lighting pattern	Description
OFF	-	LED turned off
ON	Continuously lit	LED turned on
Blinking	1 Hz	Slow and continuous blinking
Flickering	10 Hz	Fast and continuous blinking

Tab. 1: Lighting patterns of the LEDs

3.4.2 LED status indicators

LED	Description	Color	Status	Status description
PWR	Operating status indicator	Green	ON	Power is supplied properly to the module
			OFF	Module is turned OFF or power supply is irregular
SYS	Operating status indicator	Green	ON	System works normally
			Flashing	Not connected or waiting for connection
			Flickering	Firmware upgrade
			OFF	System does not work
1 ... 7	Channel display	Yellow	ON	The channel has a signal input
			OFF	The channel has no signal input

Tab. 2: Diagnostic capabilities by means of status indicators

3.5 Nameplate

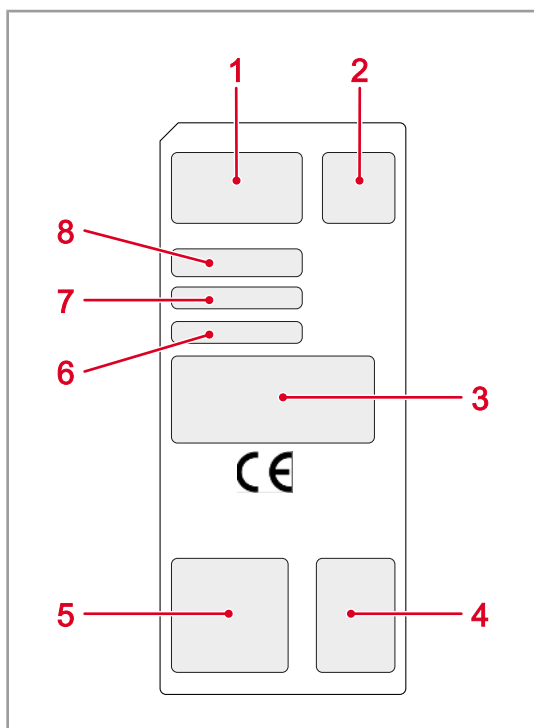

Fig. 3: Nameplate

1	Company logo
2	QR code pointing to Website
3	Power data
4	Warning and mandatory signs
5	Data Matrix Code with product information
6	Serial number
7	Item number
8	Item name

3.6 Scope of delivery

Scope of delivery	Item number	Quantity
JX4-CNT8	10002736	1

4 Technical specifications

This chapter contains the electrical and mechanical data as well as the operating data for the JX4 counter module.

4.1 Dimensions

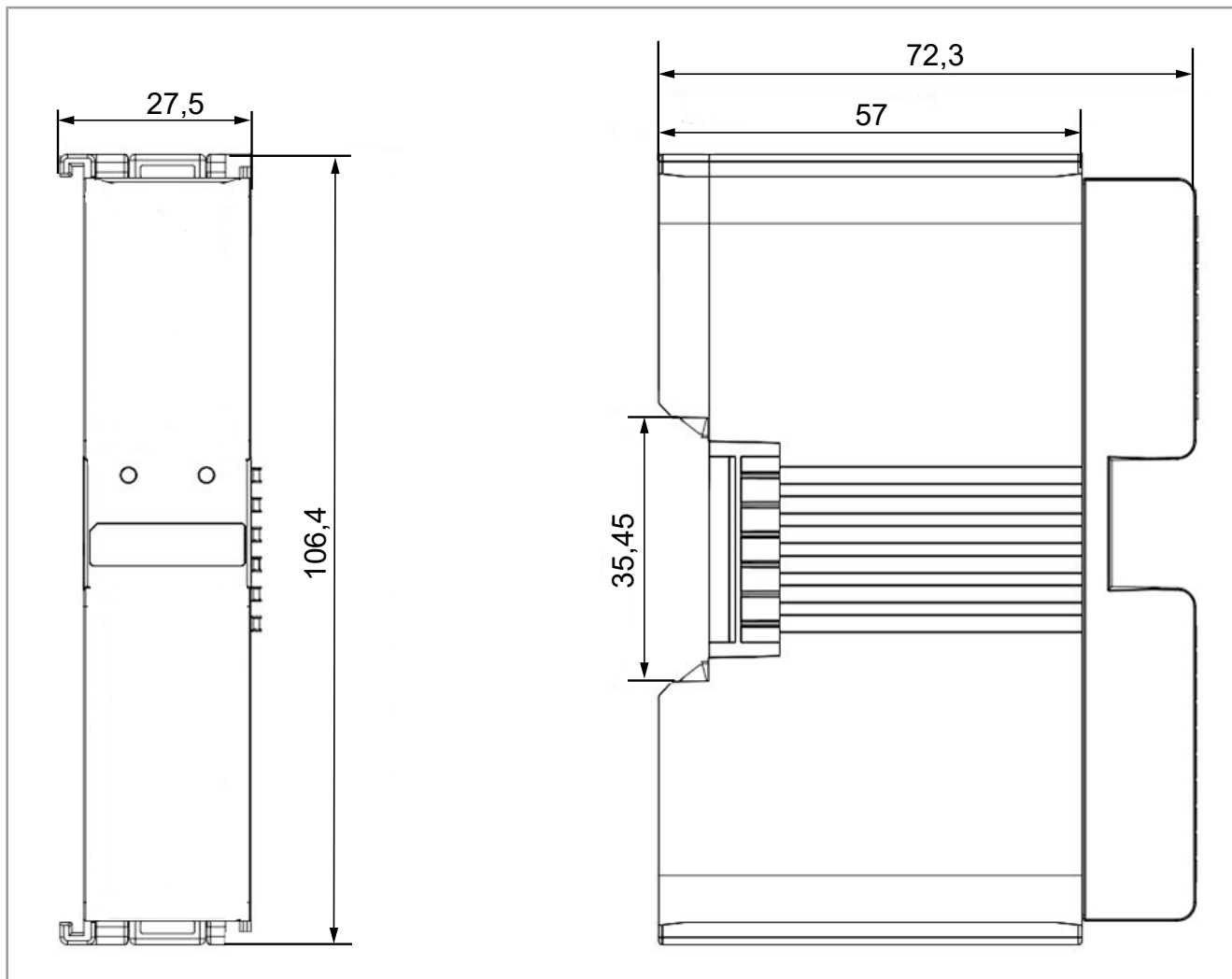

Fig. 4: Dimension in mm

4.2 Mechanical specifications

Parameter		Description	Standards
Mounting orientation		Vertically mounted on DIN rail	
Weight	Expansion module with 8 channels	85 g	
Housing specifications			
Material		Plastic	
Maximum drop height			
with shipping packaging		1 m	DIN EN 61131-2
with product packaging		0.3 m	DIN EN 60068-2-31
Vibration resistance			
Frequency sweeps		1 octave/minute, sinusoidal	DIN EN 61131-2 DIN EN 60068-2-6
Constant amplitude		3,5 mm	5 Hz ≤ f ≤ 8,4 Hz
Constant acceleration		1 g	8.4 Hz ≤ f ≤ 150 Hz
Number and direction		10 sweeps for all 3 spatial axes	
Shock resistance			
Type of shock		Half-sine wave	DIN EN 61131-2 DIN EN 60068-2-27
Intensity and duration		15 g for 11 ms	
Number and direction		3 shocks in the directions of all 3 spatial axes	
Degree of protection			
Degree of protection		IP20	DIN EN 60529

Tab. 3: Mechanical specifications of the counter module

4.3 Electrical properties

Parameter	Description
Channels	8
Type	Impulse input channel
Nominal voltage of the input channel	DC 24 V (15 V ... 30 V)
Pulse input frequency range	0 ... 100 kHz
Pulse input count value range	0 ... 2 ³² -1
Refresh rate	1 ms
Logic voltage of the system bus	DC 5 V (-15% ... +10%)
Rated current consumption	80 mA
Power consumption	0,4 W

Tab. 4: Electrical properties of counter module

4.4 Environmental conditions

Parameter	Description	Standards
Operating temperature	-20 °C ... +60 °C	DIN EN 61131-2
Storage temperature	-40 °C ... +80 °C	DIN EN 60068-2-1
Humidity	10 % ... 95 %, non-condensing	DIN EN 60068-2-2
Maximum operating altitude	2,000 m above sea level	DIN EN 61131-2
Corrosion immunity and chemical resistance	No special anti-corrosion precautions have been taken. The ambient air must not contain higher concentrations of acids, alkaline solutions, corrosive agents, salts, metal vapors and other corrosive or electroconductive contaminants.	
Degree of pollution – Electronics	Level 2	DIN EN 61131-2
	Usually, the pollution is non-conductive. However, temporary conductivity due to condensation may occur.	

Tab. 5: Environmental conditions

4.5 EMC Values

Emitted interference

Parameter	Values	Standards
Frequency band	30 MHz ... 230 MHz	DIN EN 61000-6-4
Limit value	50 dB ($\mu\text{V/m}$) at 3 m distance	DIN EN 61131-2
Frequency band	230 MHz ... 1,000 MHz	DIN EN 55011
Limit value	57 dB ($\mu\text{V/m}$) at 3 m distance	
	Class A	

Tab. 6: Emitted interference

Immunity to interference

Parameter	Values	Standards
Magnetic field with mains frequency		
Frequency	50 Hz	DIN EN 61131-2
Magnetic field	30 A/m	DIN EN 61000-6-2 DIN EN 61000-4-8
RF field, amplitude-modulated		
Frequency band	80 MHz ... 2 GHz	DIN EN 61131-2
Test field strength	10 V/m	DIN EN 61000-6-2
	AM 80 % with 1 kHz	DIN EN 61000-4-3
	Criterion A	
ESD		
Discharge through air	8 kV	DIN EN 61131-2
Test peak voltage		DIN EN 61000-6-2
Contact discharge	4 kV	DIN EN 61000-4-2
Test peak voltage	Criterion A	

Tab. 7: Immunity to interference

5 Mechanical installation

This chapter describes how to install and replace the device.

NOTICE



Damaged devices

Damaged devices may cause considerable physical damage.

- ▶ Check the device for external damage and faulty connections.
- ▶ Ensure to install only fully functional devices.

5.1 Order and arrangement

The following guidelines apply for arranging and installing the devices:

- The devices can be mounted on the DIN rail side by side with no gaps between them.
- The devices must be installed in the following order from left to right: JX4-BN-EC – I/O modules – end cover.

5.2 Installing the device on the DIN rail

NOTICE



Functional impairment due to incorrect installation

- ▶ Install the device only in vertical position on the DIN rail (DIN EN 60715).
- ▶ To allow for sufficient venting, ensure a minimum distance of 50 mm above and below the module.

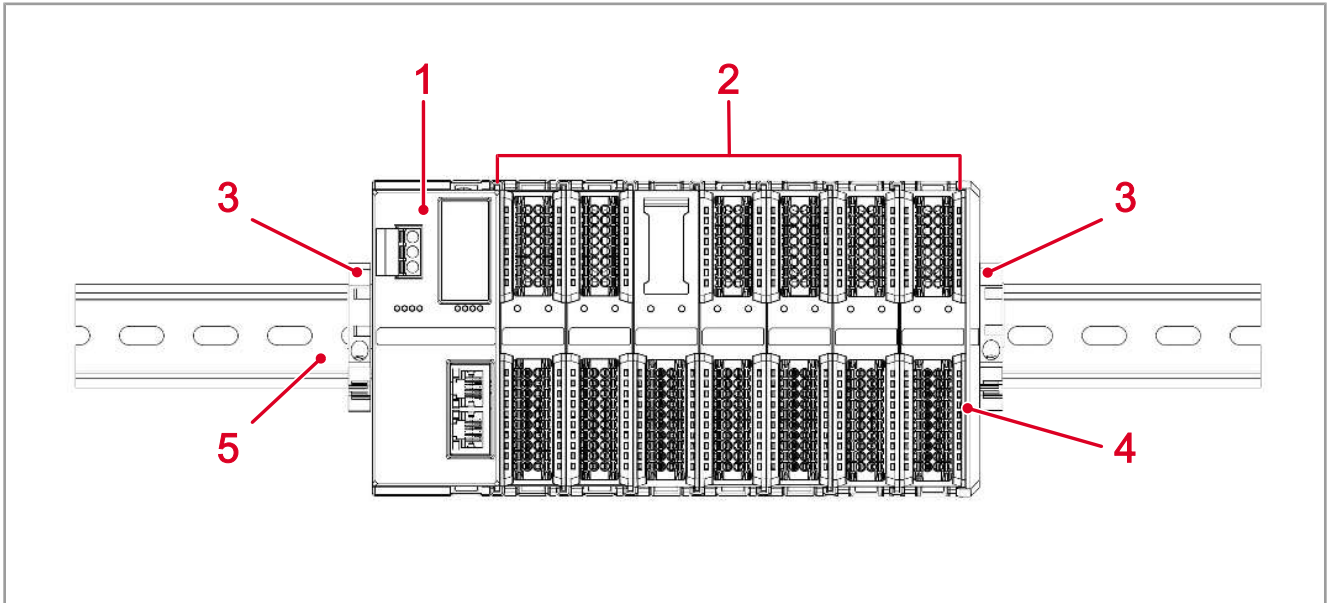
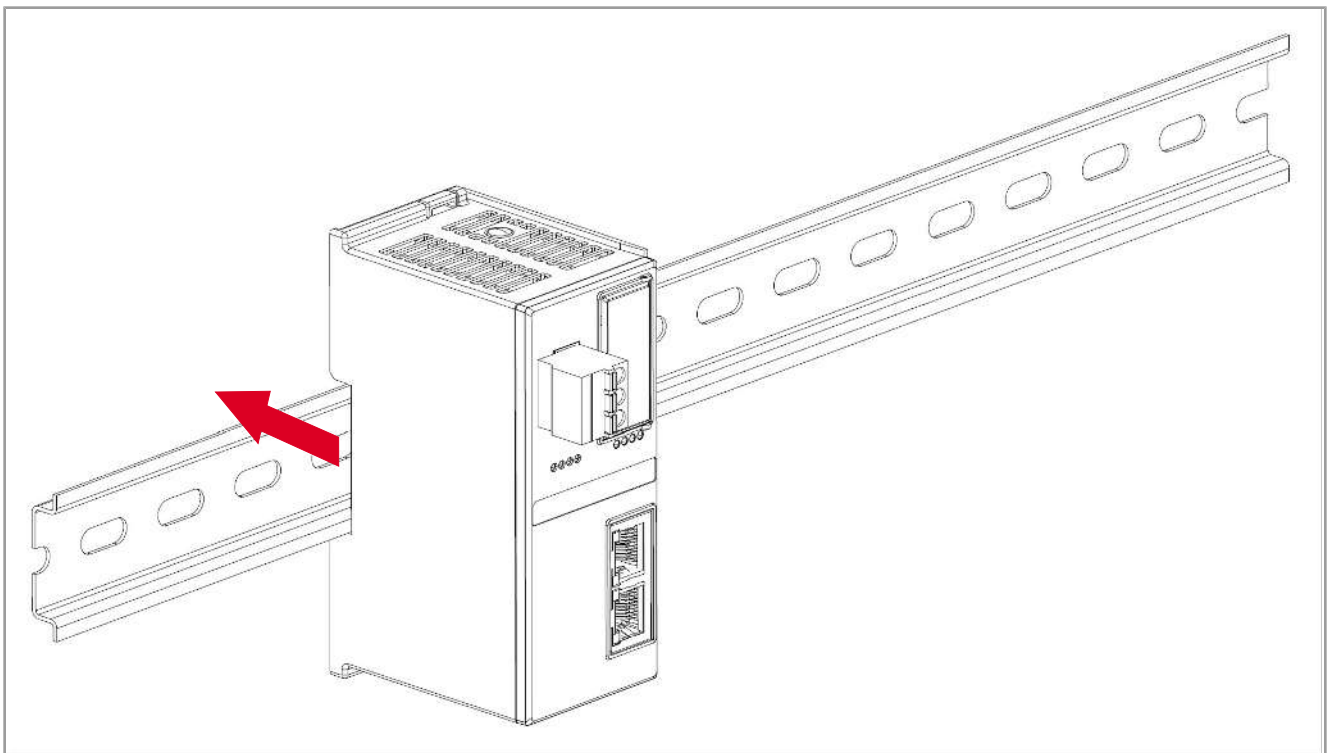

Fig. 5: System overview

1	Bus node
2	Expansion modules
3	Clamping parts
4	End cover
5	DIN rail

1. De-energize the system.
2. Align the device vertically on the DIN rail.



3. Press the device toward the DIN rail.
4. Listen for it to click into place.

5.3 Assembling the expansion module

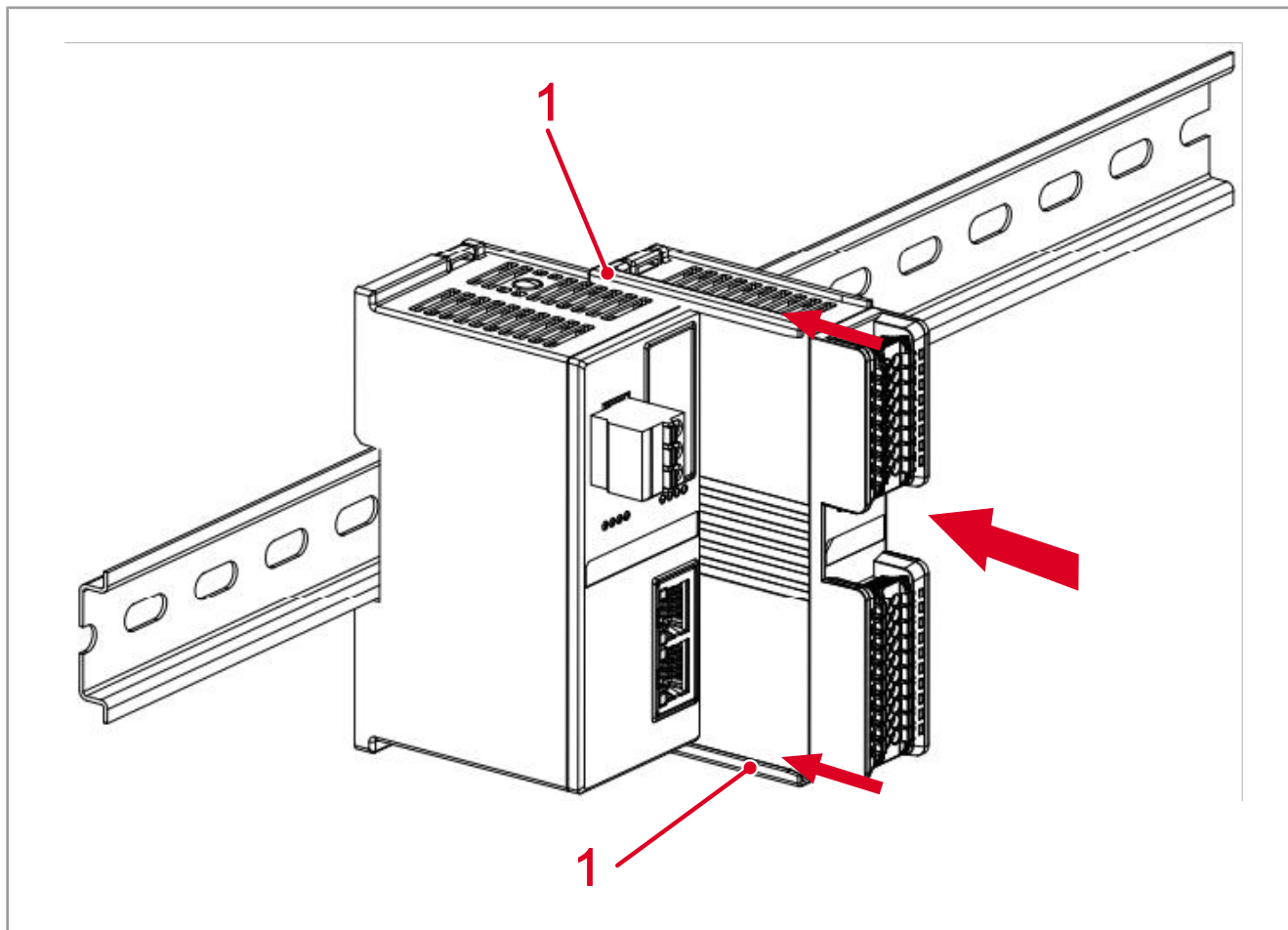

Fig. 6: Assembling the expansion module

1	Guide rail
---	------------

1. Add expansion modules to complement the device.
2. Align the guide rails (1) and push the devices back until they click into place.

5.4 Installing the end cover and retainers

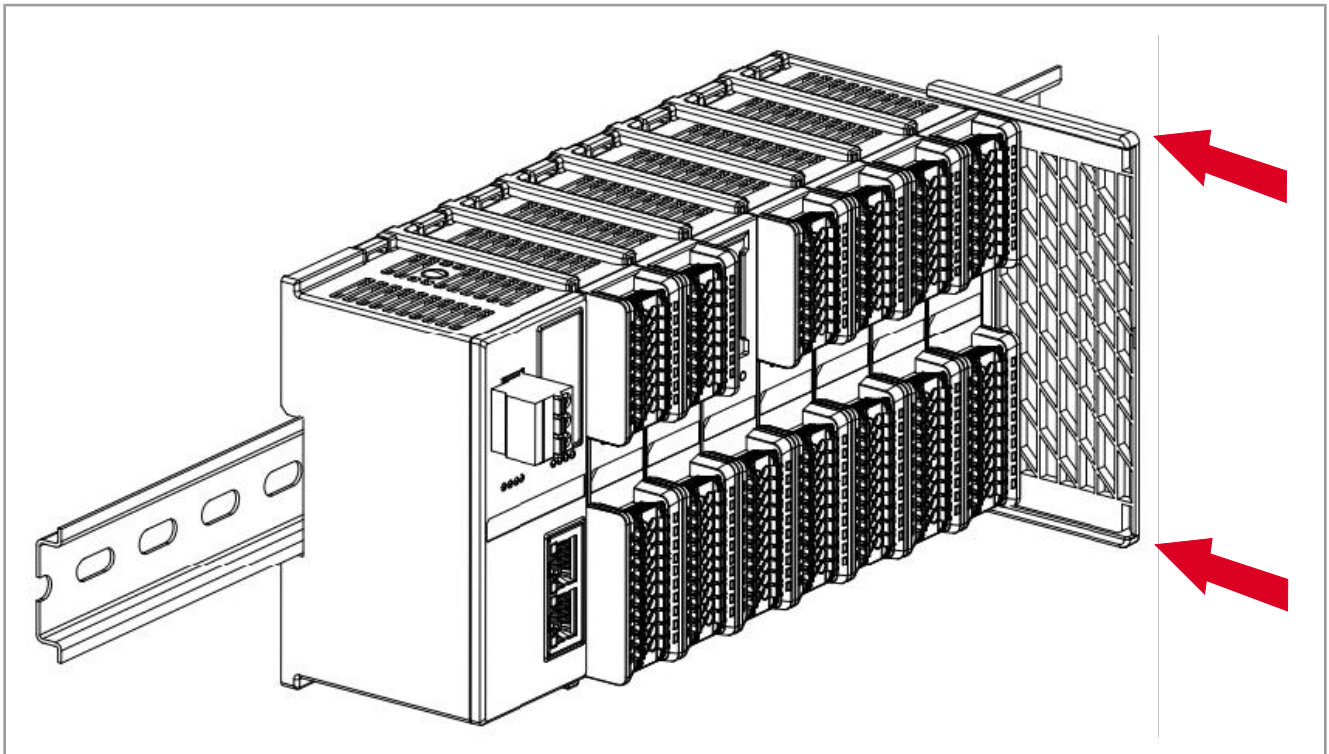

Fig. 7: Installing the end cover

1. Install the end cover on the right-hand side next to the last expansion module. The grooved surface faces toward the expansion module.

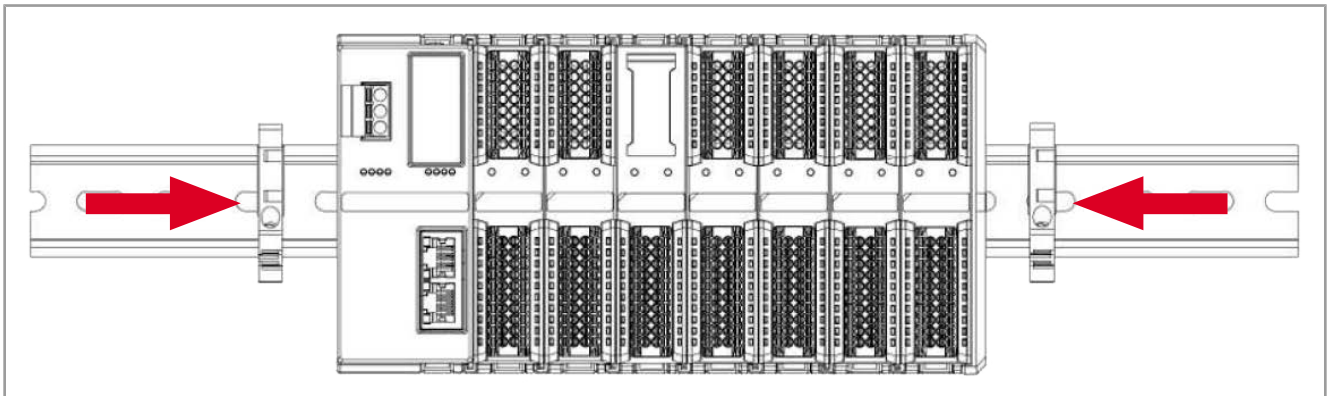

Fig. 8: Installing the retainers

2. Place the retainers on both sides of the assembly and push them firmly against the devices.

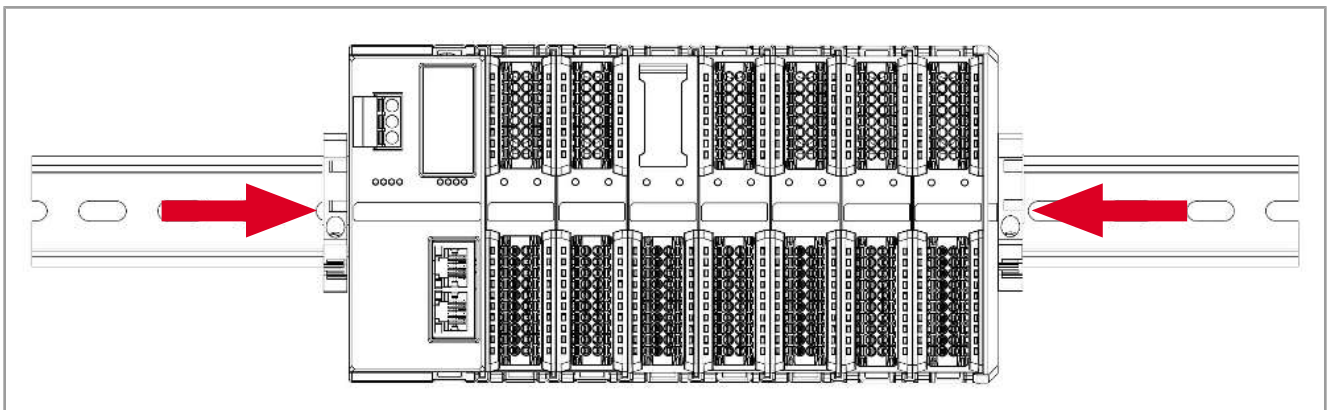

Fig. 9: Retainers firmly in place

3. Lock both retainers with a screwdriver.

5.5 Removing the device from the DIN rail

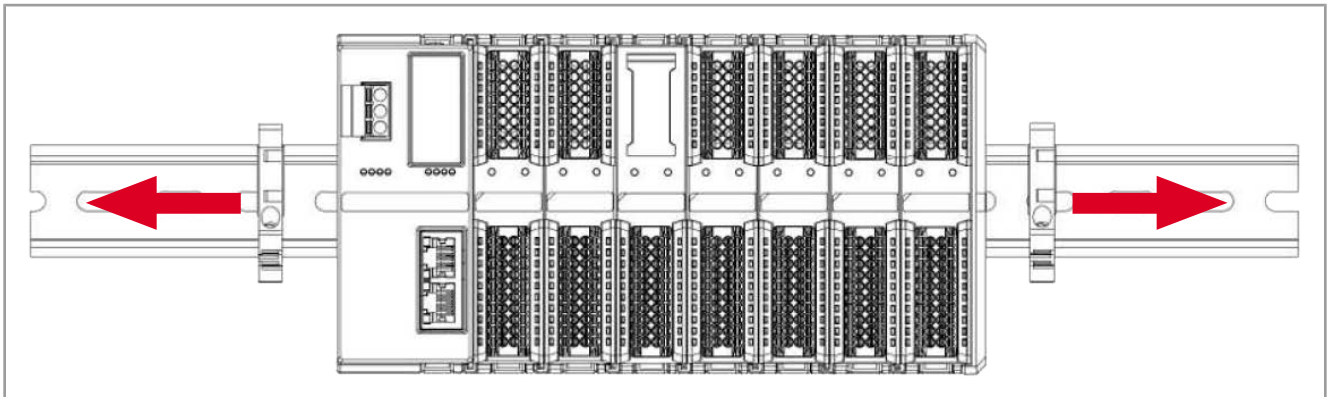

Fig. 10: Removing the retainers

1. De-energize the system.
2. Remove the retainers.

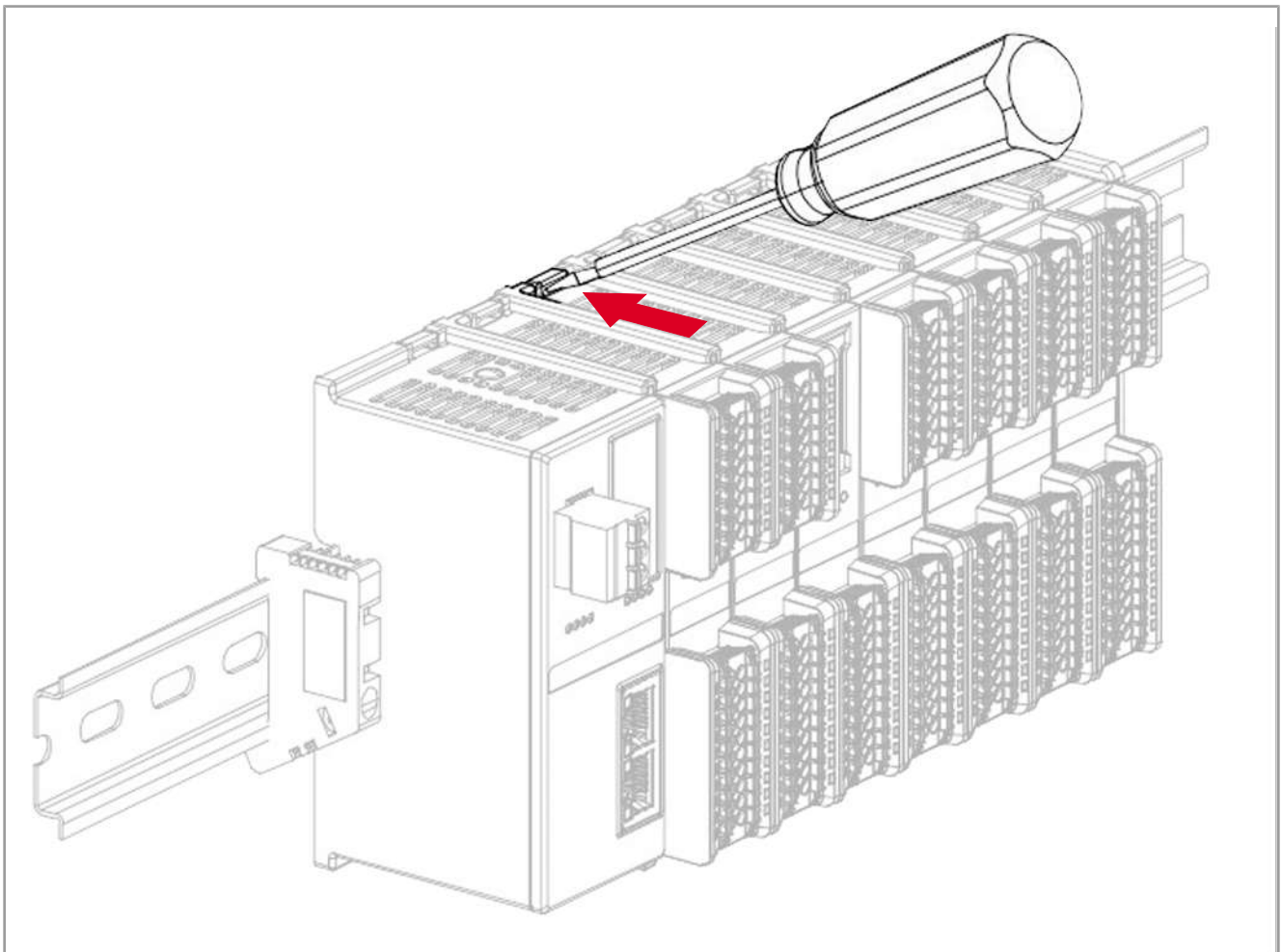

Fig. 11: Place a screwdriver on the latch.

3. Push the screwdriver into the latch.

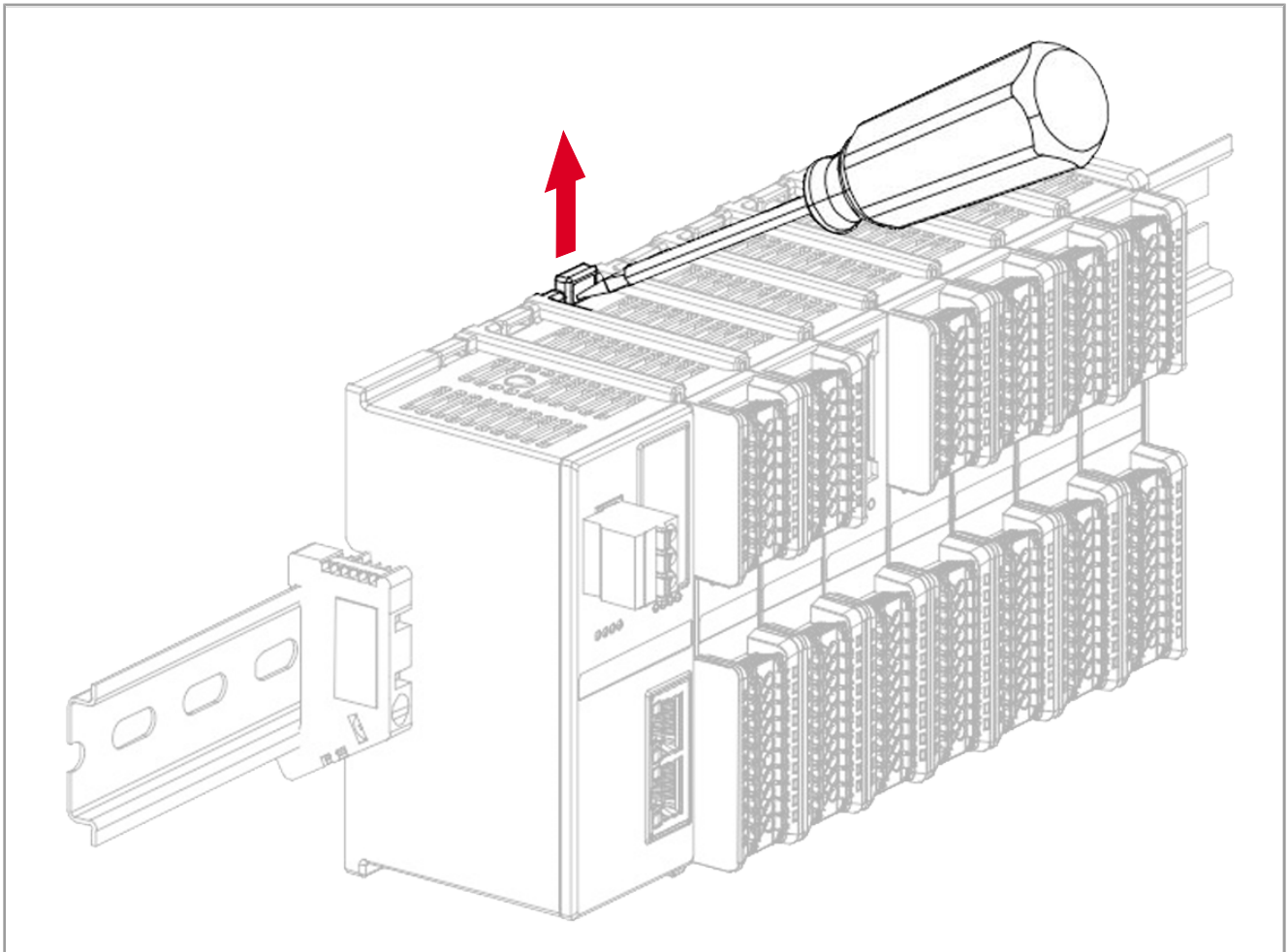

Fig. 12: Loosening the latch

4. Loosen the latch.

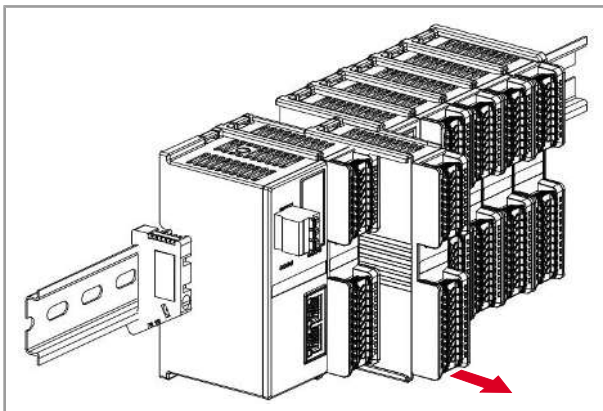

Fig. 13: Removing the module

5. Pull the device toward you and off the rail.

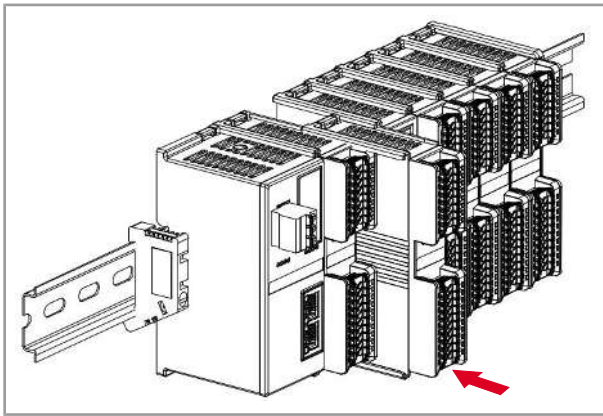
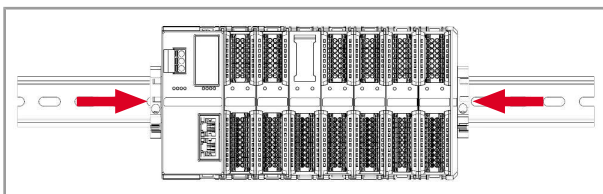
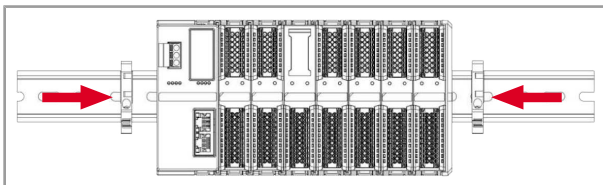

Fig. 14: Inserting the module

6. Insert a new device.



7. Install the retainers to secure the assembly.

6 Electrical connection

NOTICE



Damages to material or functional impairment

Improper implementation of the wiring harness may cause mechanical stress.

- ▶ Protect the cables from bending, twisting or chafing.
- ▶ Install strain reliefs for the connecting cables.

6.1 Improving EMC Noise Immunity

A system's immunity to noise is determined by its weakest component. Key factors are correct connections, lines and proper shielding. Observe the measures set out in this chapter.

Info

Further information

For further information on the noise immunity of a system, please refer to the Application Note 016 *EMC-Compatible Installation of the Electric Cabinet* available for download on www.bucherautomation.com.

DIN rail

- Mount the JX4-CNT8 device on a DIN rail sized 35 mm x 7.5 mm as per DIN EN 60715.

Application Note 016

Follow the instructions given in Application Note 016 *EMC-Compatible Installation of the Electric Cabinet*.

The following instructions are excerpts from Application Note 016:

- Keep signal and power lines **separated from each other** at all times. Bucher Automation AG recommends that there be a minimum distance of 20 cm. Cables and lines should cross each other at an angle of 90°.
- Shield the following cables and lines:
 - Analog lines
 - Data lines
 - Motor cables coming from inverter drives (servo output stage, frequency converter)
 - Lines between components and interference suppressor filter, where the suppressor filter is located not immediately adjacent to the component.
- Place the shield **on both sides**.
- Keep unshielded wire ends of shielded cables as short as possible.
- Span the shield **entirely** across the isolation. For **wide-area grounding**, clamp it down tightly with an extensively earthed strain relief.

6.2 Wiring

Parameter	Signal cable terminals (input and output terminals)
Voltage rating	200 V
Rated current	9.5 A
Number of pins	16P + 20P
AWG	22 ... 17
Terminal range	0.3 ... 1.0 mm ²
Stripping length	10 mm

Tab. 8: Specification of connection terminals

6.3 Block diagrams

6.3.1 JX4-CNT8

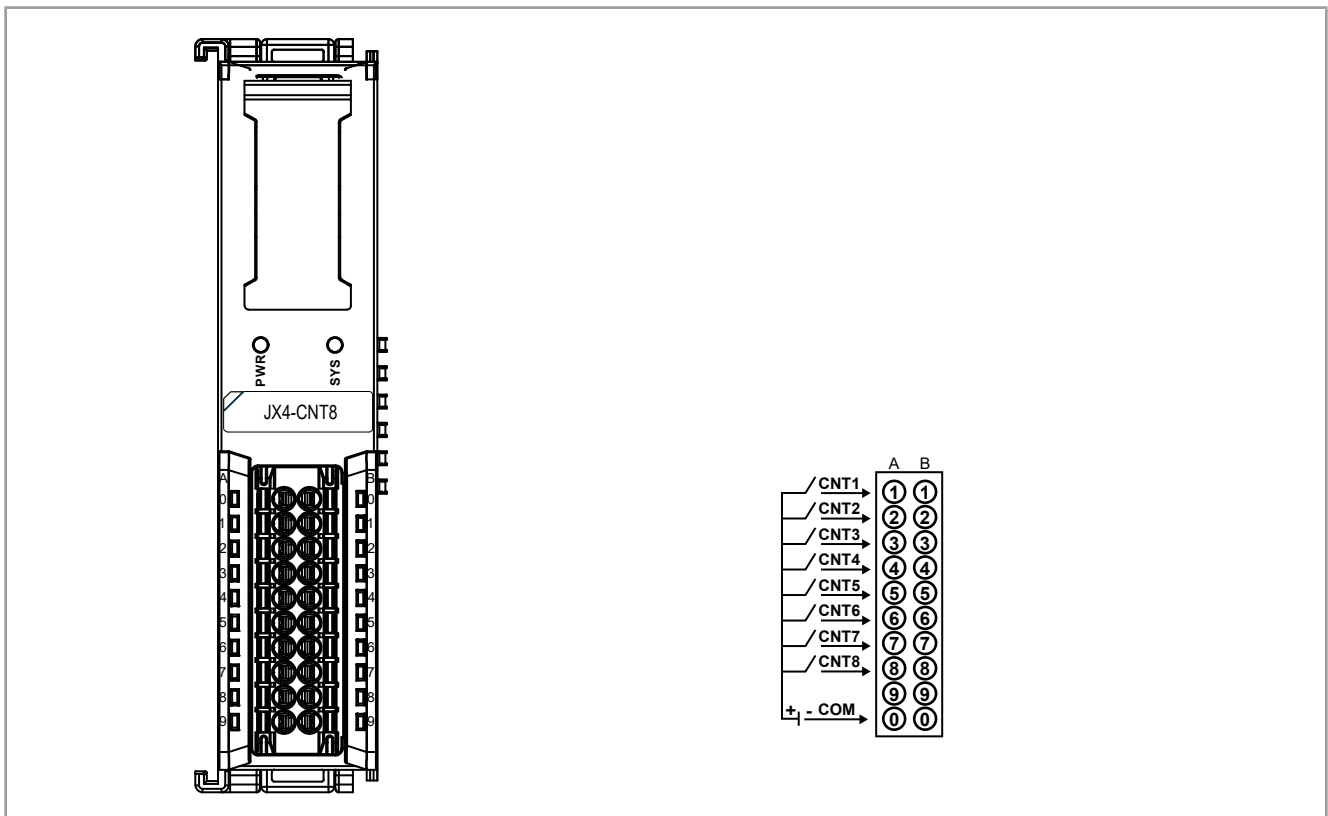

Fig. 15: JX4-CNT8 block diagram

7 Identification and configuration

Requirements

- The JetSym software version 6.1 or higher has been installed.

i Info

Further information

For more information, refer to the JetSym online help.

7.1 Incorporating an EtherCAT® device as 3rd-party

i Info

Order of device configuration

It is mandatory that the bus node be added prior to adding any expansion modules.

For further information refer to the JX4-BN-EC user manual available for download on the homepage. Go to www.bucherautomation.com and open *Products > Expansion modules > JX4 modules*.

7.2 Adding expansion modules

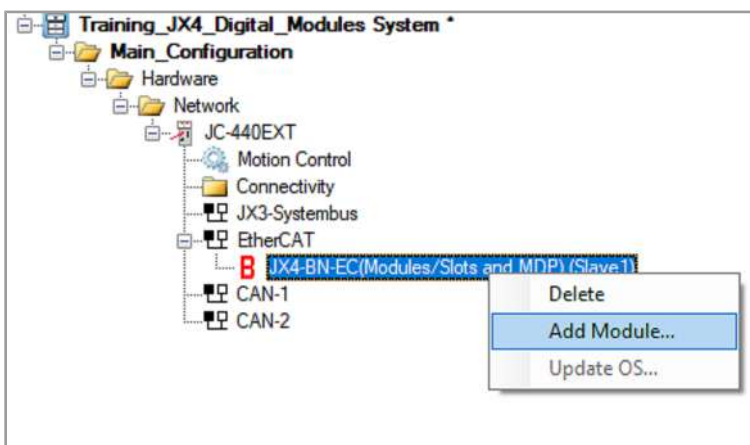

1. Go to Hardware>Network and open the node of the respective controller.
2. Open the EtherCAT submenu.
3. Right-click the JX4-BN-EC folder to open the context menu.
4. Select Add module.

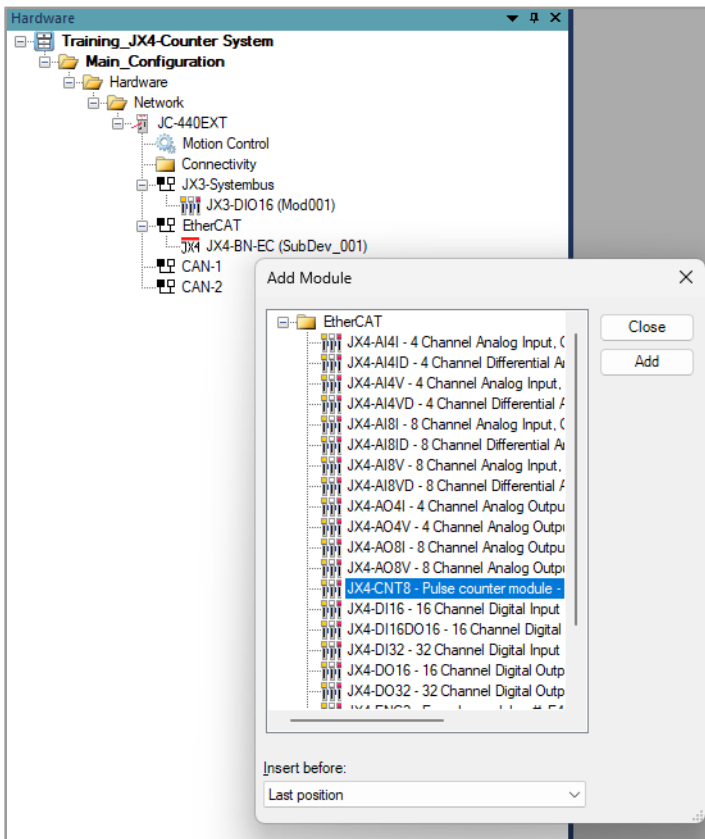

5. One by one, select the desired modules and click Add.

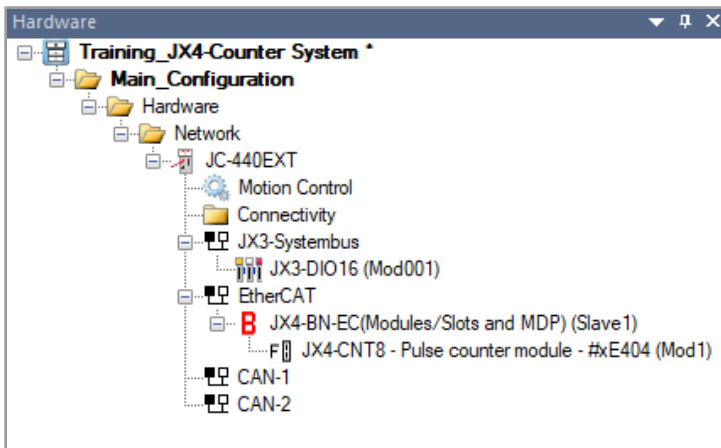

⇒ The chosen modules are shown in the list.

8 Programming

8.1 Incorporating the files in the project

1. Double-click the Training_JX4-Counter System.stxpfile to open it.

```

Gehe zu:
1  #include "bus\JX4\BN-EC.stxp"
2  #include "bus\JX4\CNT8.stxp"
3
4
5  task mainTask autorun
6
7      // create something great
8
9  end_task
10

```

2. Use `#include` to incorporate the support files in the project.

```

Gehe zu:
1  #include "bus\JX4\BN-EC.stxp"
2  #include "bus\JX4\CNT8.stxp"
3
4
5  // SPDOAddr_Slave1 is defined in the Devices_Const.stxp
6  #define JX4_BN_EC_DeviceId SPDOAddr_Slave1
7
8  var
9      // create object for JX4-BN-EC
10     Slave1 : JX4_BN_EC_BusNode(JX4_BN_EC_DeviceId);
11     // create object for counter module
12     Mod1 : JX4_CNT8_ModuleOfBusNode(Slave1, 1);
13     // create objects for the counter inputs
14     MyCounter1 : JX4_CNT8_Input(Mod1, 1);
15     MyCounter2 : JX4_CNT8_Input(Mod1, 2);
16
17 end_var
18
19
20 task mainTask autorun
21
22     // create something great
23
24 end_task
25

```

3. Create objects for the modules.

8.2 Configuring the objects and modules

The I/O modules are configurable.

8.2.1 Definition of configuration parameters

The module configuration has 1 parameter. The configuration parameters of the 8 channels are identical and can be set independently of each other.

8.2.2 Configuration of the filter level

- When a channel is disabled, the module supports configuration of the filter level of the corresponding channel in the range from 0 to 15.
- A higher filter level means a longer filter time.

NOTICE! The default filter level is filter level 7. When setting the filter level parameters, all channels must be disabled.

Support file configuration of the filter level

```

//*****
//* Enumeration with the different filter levels of the counter module channels
//*****
// the filter works in a range of a few microseconds pulse width
type
  JX4_CNT8_FILTER : enum(Level_0 = 0, Level_1 = 1, Level_2 = 2, Level_3 = 3, Level_4 = 4, Level_5 = 5, Level_6 = 6, Level_7 = 7,
                        Level_8 = 8, Level_9 = 9, Level_10 = 10, Level_11 = 11, Level_12 = 12, Level_13 = 13, Level_14 = 14, Level_15 =15)
-end_type
    
```

All setting options for configuring the filter level are stored in the support file.

- ▶ Enter the code for the desired filter level in the configuration.

8.3 Process data

8.3.1 Input data

– CNT1 ... CNT8 with count value and frequency

Parameter	Description	Value range	Data type	Length
CNT[n] count value	Pulse input count value <ul style="list-style-type: none"> – When the channel is activated and a pulse input is present at the pulse input channel, the pulse count value can be determined by sampling and analysis. – If the delete signal is set to "1," the pulse count data is deleted 	0 ... 2 ³² -1	UDINT	4 bytes
CNT[n] frequency	Pulse input frequency <ul style="list-style-type: none"> – When the channel is activated and a pulse input is present at the pulse input channel, the pulse frequency can be determined by sampling and analysis. – If there is no pulse input, the frequency is 0. 	0 ... 100000 Hz	UDINT	4 bytes

Tab. 9: Input data

8.3.2 Output data

– Activate CNT1 ... CNT8 with channel and delete the data from the count value and frequency

Parameter	Description	Value	Data type	Length
CNT[n] Enable	Activate channel <ul style="list-style-type: none"> – When the channel enable of a pulse input channel is set to "1," the channel begins sampling and analyzing the input pulse to determine the count value and pulse frequency. – When the channel enable of a pulse input channel is set to "0," the channel stops counting and measuring the frequency of the input pulses. 	0: the corresponding channel is disabled 1: the corresponding channel is activated	bool	1 bit
CNT[n] Clear Data	Delete pulse data <ul style="list-style-type: none"> – When the enable for deleting the pulse data of a pulse input channel is set from "0" to "1," the frequency and count value of the channel are deleted. 	0: Frequency and count value are displayed normally 1: Frequency and count data are deleted	bool	1 bit

Tab. 10: Output data

8.4 Declare inputs and outputs

The address data must be declared for each input and output channel.

Address syntax

1. Name of the JX4-BN-EC (slave1)
2. Name of the module (JX4-CNT8 Mod1)
3. Name of the PDO (either output or input)
4. Name of the PDO entry for input 'CNT1 Count Value' to 'CNT8 Count Value' and 'CN1 Frequency' to 'CNT8 Frequency' and for output 'CNT1 Enable' to 'CNT8 Enable' and 'CNT1 Clear Data' to 'CNT8 Clear Data'

Procedure

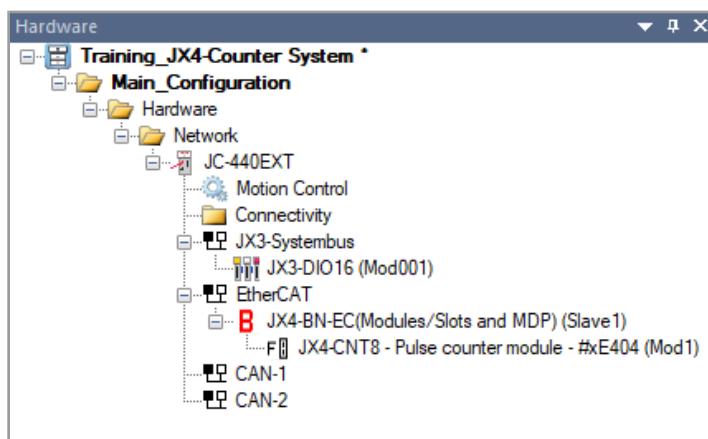

1. Go to Hardware>Network and open the node of the respective controller.

2. Open the EtherCAT submenu.
3. Double-click the desired module JX4-CNT8.

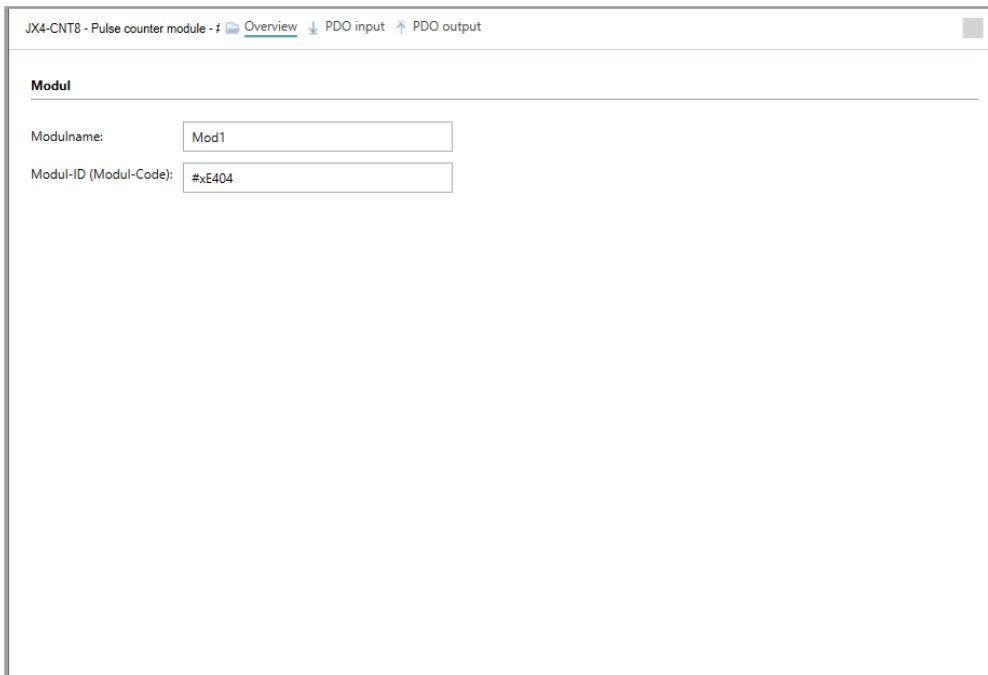

⇒ The overview page for Configuration>I/O Mapping opens.

4. Click on PDO input.

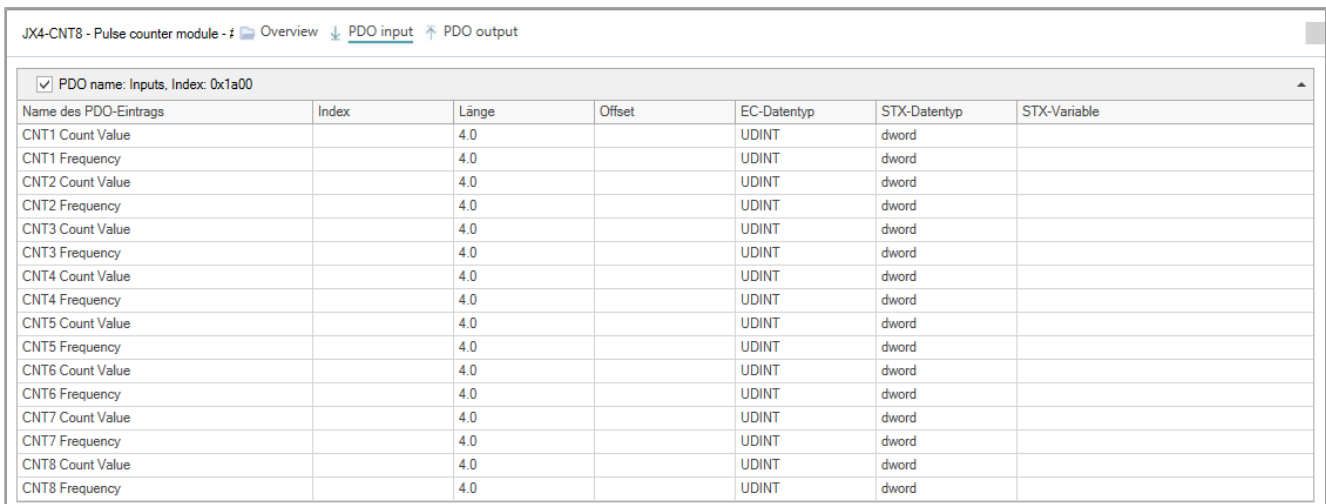
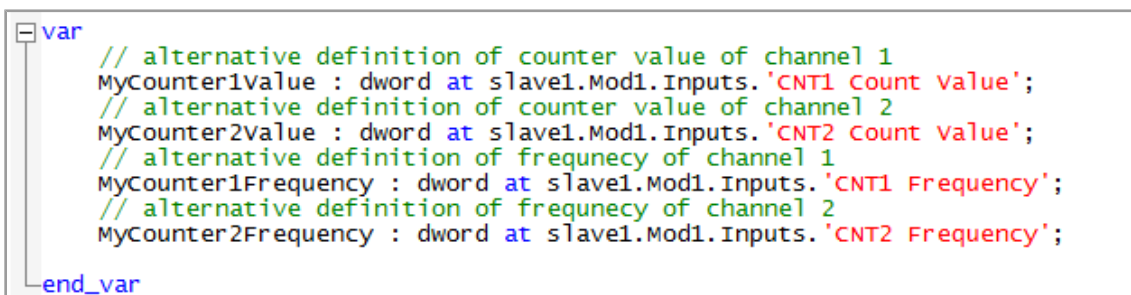

Fig. 16: List of all input addresses for the channels

⇒ The list of all input addresses for the channels opens.



5. For each channel, enter the corresponding code as described above.
6. Click on PDO output.

JX4-CNT8 - Pulse counter module - # Overview ↓ PDO input ↑ PDO output

PDO name: Outputs, Index: 0x1600

Name des PDO-Eintrags	Index	Länge	Offset	EC-Datentyp	STX-Datentyp	STX-Variable
CNT1 Enable		0.1		BOOL	bool	
CNT2 Enable		0.1		BOOL	bool	
CNT3 Enable		0.1		BOOL	bool	
CNT4 Enable		0.1		BOOL	bool	
CNT5 Enable		0.1		BOOL	bool	
CNT6 Enable		0.1		BOOL	bool	
CNT7 Enable		0.1		BOOL	bool	
CNT8 Enable		0.1		BOOL	bool	
CNT1 Clear Data		0.1		BOOL	bool	
CNT2 Clear Data		0.1		BOOL	bool	
CNT3 Clear Data		0.1		BOOL	bool	
CNT4 Clear Data		0.1		BOOL	bool	
CNT5 Clear Data		0.1		BOOL	bool	
CNT6 Clear Data		0.1		BOOL	bool	
CNT7 Clear Data		0.1		BOOL	bool	
CNT8 Clear Data		0.1		BOOL	bool	

Fig. 17: List of all output addresses of the channels

⇒ The list of all output addresses for the channels opens.

```

var
    // alternative definition of counter 1 enable
    MyCounter1Enable : bool at slave1.Mod1.Outputs.'CNT1 Enable';
    // alternative definition of counter 2 enable
    MyCounter2Enable : bool at slave1.Mod1.Outputs.'CNT2 Enable';
    // alternative definition of channel 1 clear data
    MyCounter1ClearData : bool at slave1.Mod1.Outputs.'CNT1 clear Data';
    // alternative definition of of channel 2 clear data
    MyCounter2ClearData : bool at slave1.Mod1.Outputs.'CNT2 clear Data';
end_var
    
```

7. For each channel, enter the corresponding code as described above.

⇒ The inputs and outputs are ready to be used as usual.

```

var
    // variables for the test
    CountValue : dword;
    Frequency : dword;
end_var

task mainTask autorun
    // disable the counter channel and reset the vaules
    MyCounter1.Enable := FALSE;
    MyCounter1.clearData := TRUE;
    MyCounter2.Enable := FALSE;
    MyCounter2.clearData := TRUE;
    // make sure that the counter inputs are disabled
    delay(t#10ms);
    // configure the filter level for each counter input
    MyCounter1.ConfigFilterwrite(JX4_CNT8_FILTER.Level_0);
    MyCounter2.ConfigFilterwrite(JX4_CNT8_FILTER.Level_15);
    // enable the counter inputs again
    MyCounter1.clearData := FALSE;
    MyCounter2.clearData := FALSE;
    MyCounter1.Enable := TRUE;
    MyCounter2.Enable := TRUE;
    // the counter inputs are ready now

    // the count value and frequency can be saved in local variables
    while true do
        CountValue := MyCounter1.CountValue;
        Frequency := MyCounter2.Frequency;
        delay(t#1s);
    end_while;
end_task;
    
```

Fig. 18: Sample configuration

9 Maintenance

This product is maintenance-free. The operation of the product does not require inspection or maintenance efforts.

9.1 Repairs

Defective components can cause dangerous malfunctions and compromise safety. Only the manufacturer is authorized to perform repair work. It is forbidden to open the product.

Product modifications

Modifications and alterations to the product and its functions are not allowed. The manufacturer exempts from liability for any modifications made to the product.

The original parts are specifically designed for the product. Parts and equipment from other manufacturers must not be used.

The manufacturer exempts from liability for any damage resulting from the use of non-original parts and equipment is excluded.

9.2 Storage and Shipment

Storage

When storing the product, observe the environmental conditions given in chapter "Technical specifications".

Shipment and packaging

The product contains electrostatically sensitive components which can be damaged if not handled properly. Damages to the product can impair its reliability.

To protect the product from impact or shock, it must be shipped in its original packaging, or in an appropriate protective ESD packaging.

If the packaging is damaged, inspect the device for any visible damage, and immediately inform your freight forwarder and Bucher Automation AG of the damage caused during shipment. It is strictly forbidden to use a product that has been damaged or dropped.

9.3 Return and Disposal

The WEEE icon (crossed-out wheeled bin) says that end users must not dispose of waste electrical and electronic equipment together with household waste, but separately in an appropriate way. Applicable local environmental directives and regulations must be complied with.

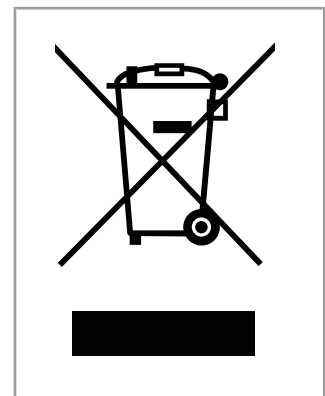

Fig. 19: WEEE icon – crossed out wheeled bin

Disposal options

To do so, you may either resort to professional disposal service providers or return waste electronics to Bucher Automation AG.

Find detailed information along with the required Return Delivery Form on our [website](#).

Batteries

Prior to disposing of waste electronics, remove any batteries where this is possible in a safe and non-destructive way. Dispose of batteries properly.

Personal data

It is the responsibility of the end user to delete any personal data stored on waste electric and electronic equipment prior to disposal.

Packaging material

The product's packaging materials must not be disposed of together with household waste. Find detailed information on how to return packaging material to Bucher Automation AG on our [website](#).

10 Service

10.1 Technical support

In case of questions, suggestions, or issues, please contact our experts from Technical Support. You may reach out by phone or through the contact form on our homepage:

[Technical Support | www.bucherautomation.com](http://www.bucherautomation.com)

Or email us:

support@bucherautomation.com

Please supply the following information when contacting Technical Support:

- Hardware revision and serial number
The hardware revision and serial number is printed on the nameplate of the product.

11 Spare parts and accessories

NOTICE



Inadequate accessories might cause damage to the product

Parts and equipment from other manufacturers might impede the function of the device and cause damage to the product.

- ▶ Only use accessories recommended by Bucher Automation AG.

List of figures

Fig. 1	System overview	8
Fig. 2	Design	9
Fig. 3	Nameplate	11
Fig. 4	Dimension in mm	12
Fig. 5	System overview	17
Fig. 6	Assembling the expansion module	18
Fig. 7	Installing the end cover	19
Fig. 8	Installing the retainers	19
Fig. 9	Retainers firmly in place	19
Fig. 10	Removing the retainers	20
Fig. 11	Place a screwdriver on the latch	20
Fig. 12	Loosening the latch	21
Fig. 13	Removing the module	21
Fig. 14	Inserting the module	22
Fig. 15	JX4-CNT8 block diagram	24
Fig. 16	List of all input addresses for the channels	30
Fig. 17	List of all output addresses of the channels	31
Fig. 18	Sample configuration	31
Fig. 19	WEEE icon – crossed out wheeled bin	32

List of tables

Tab. 1	Lighting patterns of the LEDs	10
Tab. 2	Diagnostic capabilities by means of status indicators	10
Tab. 3	Mechanical specifications of the counter module	13
Tab. 4	Electrical properties of counter module	13
Tab. 5	Environmental conditions	14
Tab. 6	Emitted interference	15
Tab. 7	Immunity to interference	15
Tab. 8	Specification of connection terminals	24
Tab. 9	Input data.....	28
Tab. 10	Output data.....	29

Bucher Automation AG

Thomas-Alva-Edison-Ring 10
71672 Marbach/Neckar, Germany
T +49 7141 2550-0
info@bucherautomation.com



www.bucherautomation.com