

# User Manual

---



---

60888134\_03

**JM-2203 / JM-2403**  
Servo amplifier

This document has been compiled by Bucher Automation AG with due diligence based on the state of the art as known to them. Any revisions and technical advancements of our products are not automatically made available in a revised document.

The Bucher Automation AG shall not be liable for any errors either in form or content, or for any missing updates, as well as for any damage or detriment resulting from such failure.



**Bucher Automation AG**

Thomas-Alva-Edison-Ring 10  
71672 Marbach/Neckar, Germany  
T +49 7141 2550-0  
[info@bucherautomation.com](mailto:info@bucherautomation.com)

Technical support

T +49 7141 2550-444  
[support@bucherautomation.com](mailto:support@bucherautomation.com)

Sales

T +49 7141 2550-663  
[sales@bucherautomation.com](mailto:sales@bucherautomation.com)

[www.bucherautomation.com](http://www.bucherautomation.com)

Translation of the german original User Manual

|               |           |
|---------------|-----------|
| Revision      | 1.03      |
| Date of issue | 4/22/2026 |

# Table of Contents

|          |   |           |
|----------|---|-----------|
| <b>1</b> | <b>Introduction.....</b>                          | <b>5</b>  |
| 1.1      | Information about the document.....               | 5         |
| 1.2      | Typographical conventions.....                    | 6         |
| <b>2</b> | <b>Safety.....</b>                                | <b>7</b>  |
| 2.1      | General.....                                      | 7         |
| 2.2      | Purpose.....                                      | 7         |
| 2.2.1    | Intended use.....                                 | 7         |
| 2.2.2    | Non-intended use.....                             | 7         |
| 2.3      | Warnings Used.....                                | 8         |
| 2.4      | General safety instructions.....                  | 9         |
| 2.5      | Safety labels.....                                | 13        |
| <b>3</b> | <b>Product description.....</b>                   | <b>15</b> |
| 3.1      | Design.....                                       | 15        |
| 3.2      | Product features.....                             | 15        |
| 3.3      | Status display.....                               | 16        |
| 3.3.1    | Diagnostic capability via the status display..... | 17        |
| 3.4      | Nameplate.....                                    | 20        |
| 3.5      | Scope of delivery.....                            | 21        |
| 3.6      | Encoder options.....                              | 22        |
| <b>4</b> | <b>Technical Specifications.....</b>              | <b>25</b> |
| 4.1      | Dimensions.....                                   | 25        |
| 4.2      | Mechanical specifications.....                    | 26        |
| 4.3      | Output motor side.....                            | 26        |
| 4.3.1    | External braking resistor.....                    | 26        |
| 4.4      | Input mains side.....                             | 27        |
| 4.4.1    | Fuse types for UL applications.....               | 27        |
| 4.5      | Ports and interfaces.....                         | 28        |
| 4.6      | Environmental conditions.....                     | 29        |
| 4.7      | External line filter.....                         | 30        |
| 4.8      | Derating.....                                     | 30        |
| <b>5</b> | <b>Mechanical installation.....</b>               | <b>32</b> |
| 5.1      | Mounting the servo amplifier.....                 | 33        |
| 5.2      | Removing the servo amplifier.....                 | 35        |
| 5.3      | Mounting the line filter.....                     | 36        |
| <b>6</b> | <b>Electrical connection.....</b>                 | <b>38</b> |
| 6.1      | EMC-compliant installation.....                   | 39        |

- 6.1.1 Line filter ..... 42
- 6.2 Removing the lower front cover ..... 43
- 6.3 Connections ..... 44
  - 6.3.1 Connection X212 – EtherCAT® ..... 46
  - 6.3.2 Connection X1 – AC voltage supply ..... 47
  - 6.3.3 Connection X2 – motor connection axis 1 ..... 48
  - 6.3.4 Connection X12 – DC 24 V supply ..... 49
  - 6.3.5 Connection X21 – motor holding brake axis 1 ..... 50
  - 6.3.6 Connection X841 – STO + SBC [S1] ..... 51
  - 6.3.7 Connection X843 – Extended safety function [S2] ..... 52
  - 6.3.8 Connection X210 – digital inputs ..... 54
  - 6.3.9 Braking resistors [-R] ..... 55
- 6.4 Encoder plug-in slots ..... 57
  - 6.4.1 Encoder option -R / -S2R – resolver ..... 58
  - 6.4.2 Encoder options -H – HIPERFACE DSL® ..... 59
  - 6.4.3 Encoder option -A – External SinCos encoder ..... 60
  - 6.4.4 Encoder option -A – HIPERFACE® analog ..... 61
  - 6.4.5 Encoder option -I – incremental encoder ..... 62
  - 6.4.6 Encoder option -E6 – EnDat® 2.2 ..... 63
- 7 Maintenance ..... 64**
  - 7.1 Repairs ..... 64
  - 7.2 Storage and Shipment ..... 64
  - 7.3 Return and Disposal ..... 65
- 8 Service ..... 66**
  - 8.1 Technical Support ..... 66
- 9 Spare parts and accessories ..... 67**
  - 9.1 Spare parts ..... 67
    - 9.1.1 Mounting hardware ..... 67
    - 9.1.2 Front covers ..... 67
    - 9.1.3 Connector sets ..... 67
  - 9.2 Accessories ..... 68
    - 9.2.1 Pre-assembled cables ..... 68
    - 9.2.2 EtherCAT® cable ..... 69
    - 9.2.3 External line filter ..... 69
    - 9.2.4 Optional external brake resistors ..... 69

# 1 Introduction

## 1.1 Information about the document

This document is part of the product and must be read and understood before using the device. It contains important and safety-related information to ensure that the product is used properly and in accordance with its intended purpose.

### Target audiences

This document is intended for qualified personnel.

The device must only be put into operation by qualified and trained personnel.

Safe use of the device must be ensured at every stage of its life cycle. A lack of or insufficient technical and documentation knowledge will result in the loss of any liability claims.

### Availability of information

Ensure that this information is readily available near the product throughout its entire service life.

Please check the Downloads section of our website for updates and the latest version of the document. This document is not subject to automatic version control.

[Start | www.bucherautomation.com](http://www.bucherautomation.com)

For further information refer to the following information products:

- Online help for the JetSym software  
Functions of software products with application examples
- Application-oriented manuals  
Product-independent documentation
- Software Updates  
Information about changes to your device's software and operating system

## NOTICE



### Related documents

When installing and connecting the servo amplifiers within the axis system, it is essential to also follow the operating instructions for the other devices as well as the *Function Description Integrated Safety Function S1 - JM-2000 and JM-D2000*. You can find the documentation at [www.bucherautomation.com](http://www.bucherautomation.com) under *Product Page JM-2203 / JM-2403 > Downloads*.

### Info

#### Further information

For more information on system immunity to interference, please refer to Application Note 016 *EMC-Compliant Control Cabinet Installation* at [www.bucherautomation.com](http://www.bucherautomation.com).

### Info

#### EtherCAT®

EtherCAT® is a registered trademark and patented technology licensed by Beckhoff Automation GmbH, Germany.

## 1.2 Typographical conventions

This manual uses different typographical effects to support you in finding and classifying information. Below, there is an example of a step-by-step instruction:

- ✓ This symbol indicates requirements which have to be met before executing the following action.
- ▶ This sign or a numbering at the beginning of a paragraph marks an action instruction that must be executed by the user. Execute the instructions one after the other.
- ⇒ The target after a list of instructions indicates reactions to, or results of these actions.

---

### Info

#### **Further information and practical tips**

In the info box you will find helpful information and practical tips about your product.

---

# 2 Safety

## 2.1 General

At the time of its release, the product reflects the current state of science and technology.

In addition to the operating instructions, the laws, regulations, and guidelines of the country of use or the EU apply to the operation of the product. The operator is responsible for complying with the relevant accident prevention regulations and generally accepted safety standards.

## 2.2 Purpose

### 2.2.1 Intended use

The JM-2203 / JM-2403 servo amplifiers are components designed for installation in industrial and commercial systems and machines. Installation is only permitted in stationary equipment. You may only use the servo amplifier in closed control cabinets meeting the requirements of IP54 or higher, taking ambient conditions into account.

When the servo amplifier is installed in a machine, commissioning (i.e., commencement of intended use) of the servo amplifier is prohibited until it has been determined that the machine is in compliance with the Machinery Directive 2006/42/EC. Commissioning (i.e., commencement of intended use) is only permitted if the EMC Directive (2014/30/EU) is complied with.

### 2.2.2 Non-intended use

Use of the servo amplifier outside of the application areas given here or under operating ranges and ambient conditions other than those described in the documentation is considered non-intended use.

- The servo amplifier must not be used outside a control cabinet.

The following application areas are considered non-intended use:

- Installation in vehicles. Use of the device in non-stationary equipment is considered an exceptional environmental condition and is only permitted after special agreement.
- Installation in environments where there are hazardous oils, acids, gases, vapors, dusts, rays, etc.
- Use in special application areas (e.g. where there is a risk of explosion, corrosion or fire).
- Untypical generation of higher frequency on-board networks.

## 2.3 Warnings Used

### DANGER



**High risk**

Indicates an imminently hazardous situation which, if not avoided, will result in death or serious injury.

### WARNING



**Medium risk**

Indicates a potentially hazardous situation which, if not avoided, could result in death or serious injury.

### CAUTION



**Low risk**

Indicates a hazardous situation which, if not avoided, could result in minor or moderate injury.

### NOTICE



**Material damage**

Indicates a situation which, if not avoided, could result in malfunctions or material damage.

## 2.4 General safety instructions

### DANGER



#### Danger due to high electrical voltage

Touching live parts may result in death or severe injuries. Carry out the following steps before starting work to ensure safety:

- ▶ Prepare for shutting off the system. Inform everyone involved who will be affected by the process.
- ▶ Isolate the drive system from the power supply and secure it against being turned on again.
- ▶ Wait for the discharge time (approx. 3 minutes) and check all power connections to ensure they are at zero potential.
- ▶ Ground according to requirements.
- ▶ Cover over neighboring live parts.
- ▶ Ensure the drives cannot move.

### DANGER



#### Danger due to high operating voltage

The high operating voltage may cause serious injury, or death.

Please follow these rules throughout the **entire work process**.

- ▶ Do not remove any cover plates and keep all control cabinet doors closed during operation.
- ▶ Check that all live connections are protected against contact.
- ▶ Do not open the device.
- ▶ Never touch the device's power supply and DC link terminals (X1, X2, and, for the JM-D2000, X3 as well) while the device is in operation.

### DANGER



#### Risk of electric arc due to improper handling

Improper handling can cause an electric arc, which can lead to serious injuries or death.

- ▶ Open the plug connections only in de-energized state.
- ▶ Install the device only in an environment where there is no risk of fire, corrosion or explosion without any flammable gases or vapors.
- ▶ Observe the specified limit values for voltage.
- ▶ Wire according to regulations.

**⚠ DANGER**



**Danger due to high electrical voltage**

According to EN 61800-5-1, connecting thermal sensors to the encoder port (extra-low voltage) within the motor requires double or reinforced insulation .

**⚠ WARNING**



**Risk of injury due to electric shock**

Triggering the STO function does not include safe electric isolation. The device or equipment is not de-energized!

- ▶ Safe electric isolation requires the installation of additional isolating equipment, e.g. a mains switch, that disconnects power supply.

**⚠ WARNING**



**Non-observance of safety instructions may result in injuries or physical damage**

- ▶ Prior to assembling and installing the device, read and follow the safety precautions and restrictions of use as set out in the Safety chapter.
- ▶ Only authorized qualified personnel is allowed to perform any kind work on the device.

**⚠ WARNING**



**Risk of crushing due to uncontrolled axis movements**

High mechanical forces due to axis movements and accelerations.

- ▶ Keep out of the hazard zone of the machines.
- ▶ Do not disable any safety equipment.
- ▶ Have malfunctions eliminated by qualified personnel.

**⚠ WARNING**



**Risk of burns due to hot surfaces**

The device may become hot during operation and can cause burns if touched.

- ▶ Take protective measures to prevent inadvertent contact with the device, e.g. protective covers.
- ▶ Make sure that no temperature-sensitive parts, e.g. connection cables, are attached or fastened to the device.
- ▶ Ensure there is adequate heat dissipation and maintain the required distances during installation so as not to prevent or restrict ventilation.
- ▶ Allow the device to cool off for a while before carrying out cleaning or maintenance work.
- ▶ Wear personal protective equipment.

**⚠ WARNING****Danger for persons with pacemakers and implants**

Operating the device generates an electromagnetic field. Electric, magnetic and electromagnetic fields are a health risk in particular to persons with pacemakers and implants.

- ▶ If you belong to the above group of persons you must not be in the immediate vicinity of the device.
- ▶ Keep a minimum distance as specified below:  
300 mm from a de-energized device, for example when doing installation work;  
600 mm from an energized device running in normal operation.

**⚠ WARNING****Risk of death due to falling loads during lifting and transport processes**

Improperly performed lifting and transport processes as well as unsuitable or defective devices and tools can lead to severe or fatal injuries and material damage.

- ▶ Lifting devices, industrial trucks and load handling attachments must meet requirements.
- ▶ The load capacity of the lifting equipment and load handling attachments must be in line with the weight of the load being transported.
- ▶ Fasten and secure the load to be transported carefully to the lifting equipment.
- ▶ Do not stand in the swivel range of lifting equipment or under suspended loads.

**⚠ WARNING****Risk of injury due to damaged safety labels**

Damaged safety labels endanger people and cause property damage. Possible consequences include severe, potentially fatal injuries caused by moving parts and/or a fatal electric shock.

- ▶ Make sure that warning signs and safety signs are clearly legible and do not go missing.
- ▶ Replace them with exact duplicates if they are damaged or lost.

**⚠ CAUTION****Risk from unwanted coastdown**

Triggering the STO function by deactivating the digital input merely interrupts the energy supplied to the drive while the motor movement can no longer be controlled.

- ▶ Always stop the drive before you trigger the STO function.
- ▶ In case of suspended loads, install a mechanical brake to prevent the load from falling down.

## NOTICE



### Damaged devices

Damaged devices may cause considerable physical damage.

- ▶ Check the device for external damage and faulty connections.
- ▶ Ensure to install only fully functional devices.

## NOTICE



### Material damage due to loose power connection

Vibrations or insufficient tightening torques can lead to loose power connections. This can lead to fire damage, defects in the device or malfunctions.

- ▶ Tighten all power connections to the specified tightening torques.
- ▶ Check all power connections at regular intervals, especially after transport.

## NOTICE



### Inadequate accessories might cause damage to the product

Parts and equipment from other manufacturers might impede the function of the device and cause damage to the product.

- ▶ Only use accessories recommended by Bucher Automation AG.

## NOTICE



### Damage due to incorrect storage

Incorrect or improper storage can lead to damage to the device, e.g. due to moisture and dirt.

- ▶ Avoid large temperature fluctuations and high humidity at the storage location.
- ▶ Protect the device against moisture and dirt during storage.
- ▶ Store the device in its original packaging.

## NOTICE



### Damage due to incorrect storage period

An improper storage period can lead to damage to the device. The duration of storage without connection to the permissible rated voltage must not exceed 1 year.

- ▶ If the storage period exceeds 1 year, connect the device to the mains voltage for 60 minutes.
- ▶ If you have any questions prior to commissioning the device, contact Bucher Automation AG.

## 2.5 Safety labels

### On the device





There is a safety label affixed to the front of the device.



Fig. 1: Safety label

The safety label includes 4 warning symbols and an indication of the discharge time.

### Meaning of the warning signs

|   |  |
|---|--|
|  | General warning sign                   |
|  | Warning: Hot surfaces                  |
|  | Warning: Electrical voltage            |
|  | Electrostatically sensitive components |

Included with the delivery



|   |   |
|---|---|
|  | <p><b>⚠ WARNING</b></p>   |
|   | <p><b>Risk of Electric Shock</b><br/>                 Discharge time of DC capacitors to a level below 50 V is 3 minutes.<br/>                 ► Read the User manual.</p>  |
|   | <p><b>⚠ AVERTISSEMENT</b></p>   |
|   | <p><b>Risque de choc électrique</b><br/>                 Le temps de décharge des condensateurs CC à un niveau inférieur à 50 V est de 3 minutes.<br/>                 ► Lire les Instructions d'utilisation.</p> |

Fig. 2: Safety Label: Discharge Time

Every device in the JM-2000family comes with the safety label shown above.

1. Affix the safety label in a **clearly visible location** near the JM-2000 devices inside the control cabinet.
2. Please note the following safety warning:

|  |  |
|--|--|
| <p><b>⚠ WARNING</b></p>  |  |
|  | <p><b>Risk of injury due to damaged safety labels</b></p> <p>Damaged safety labels endanger people and cause property damage. Possible consequences include severe, potentially fatal injuries caused by moving parts and/or a fatal electric shock.</p> |
|  | <ul style="list-style-type: none"> <li>► Make sure that warning signs and safety signs are clearly legible and do not go missing.</li> <li>► Replace them with exact duplicates if they are damaged or lost.</li> </ul>                                  |

## 3 Product description

The JM-2203 / JM-2403 is a modularly structured servo amplifier with an EtherCAT® bus connection.

### 3.1 Design

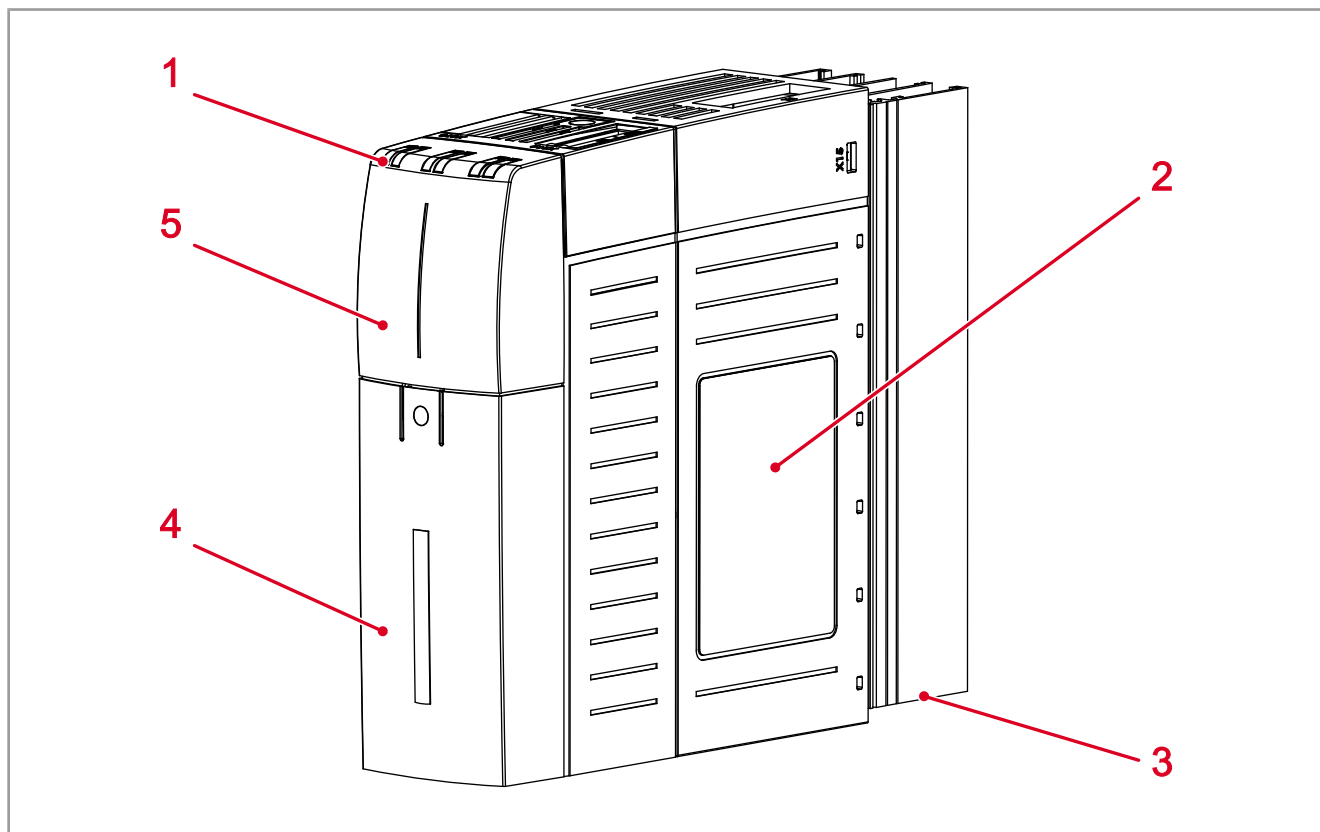

Fig. 3: Design

|   |                          |
|---|--------------------------|
| 1 | Status indication [► 16] |
| 2 | Nameplate [► 20]         |
| 3 | Integrated fan           |
| 4 | Lower front cover        |
| 5 | Upper front cover        |

### 3.2 Product features

- Modular design
- Compact dimensions
- 1 axis per device
- STO (S1) integrated in the standard configuration
- Built-in braking resistor (R1)
- 3 times nominal current for 3 s
- 2 times nominal current for 60 s
- High positioning accuracy
- Easy commissioning by means of the JetSym application software and a JetControl controller

### 3.3 Status display

The LEDs of the status display indicate the states of the safety functions and the amplifier.

The display differs depending on the safety system being installed (S1 or S2).

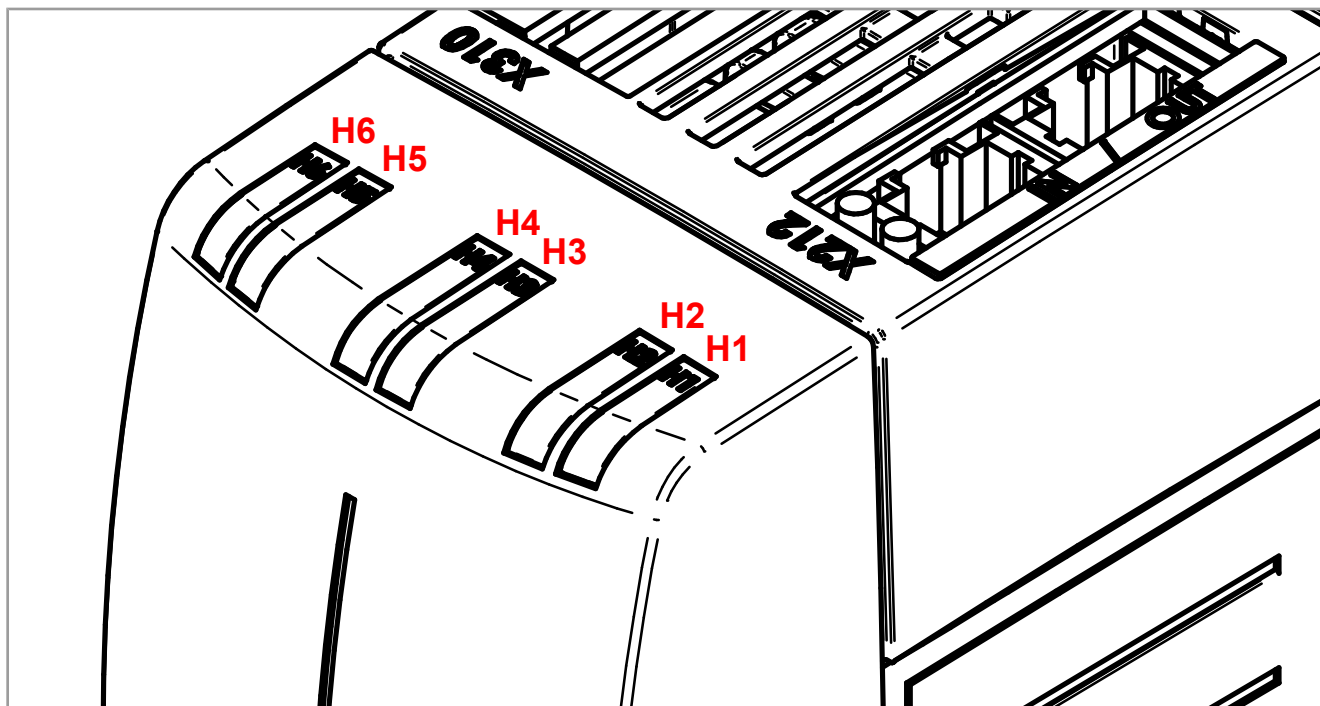

Fig. 4: Status indication

| LED     | Safety function S1        | Safety function S2        |
|---------|---------------------------|---------------------------|
| H1      | Amplifier status – axis 1 | Amplifier status – axis 1 |
| H2      | -                         | -                         |
| H3      | Safety status – axis 1    | Safety status – axis 1    |
| H4      | -                         | Safety status – axis 1    |
| H5 / H6 | -                         | -                         |

### 3.3.1 Diagnostic capability via the status display

#### Amplifier status LEDs



| LED                           | H1                             |                  | Description   |
|-------------------------------|--------------------------------|------------------|---|
| <b>Color</b>                  | Red / green                    |                  | Programming phase   |
| <b>Status</b>                 | Blinking at 4 Hz               |                  |   |
| <b>Color</b>                  | Orange                         |                  | Initialization phase  |
| <b>Status</b>                 | ON                             |                  |   |
| <b>Color</b>                  | Green                          | Orange           | Voltage is applied (DC 24 V).   |
| <b>Status without warning</b> | Flashing at 2 Hz / 0.5 s pause | -                |   |
| <b>Status with warning</b>    | Flashing at 2 Hz / 0.5 s pause | Blinking at 1 Hz |   |
| <b>Color</b>                  | Green                          | Red              | Preparation for controlled operation (Bootstrap, ShortCircuitTest, OffsetAdjustIADCs, FlyingStart, Magnetization) |
| <b>Status without warning</b> | Blinking at 4 Hz               | -                |   |
| <b>Status with warning</b>    | Blinking at 4 Hz               | Blinking at 1 Hz |   |
| <b>Color</b>                  | Green                          | Green / orange   | Controlled operation including stop and quick stop  |
| <b>Status without warning</b> | ON                             | -                |   |
| <b>Status with warning</b>    | -                              | Blinking at 1 Hz |   |
| <b>Color</b>                  | Red / green                    |                  | Error response is active.   |
| <b>Status</b>                 | Blinking at 4 Hz               |                  |   |
| <b>Color</b>                  | Red                            |                  | Error that cannot be acknowledged   |
| <b>Status</b>                 | ON                             |                  |   |
| <b>Color</b>                  | Red                            |                  | Waiting for error acknowledgment.   |
| <b>Status</b>                 | Blinking at 1 Hz               |                  |   |

Safety status LEDs

Safety function S1

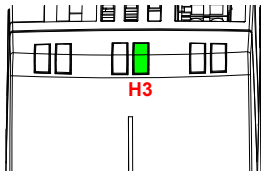

| LED    | H3               | Description  |
|--------|------------------|--|
| Color  | Green            | STO is not active.   |
| Status | ON               |  |
| Color  | Green            | STO is active.   |
| Status | Blinking at 1 Hz |  |
| Color  | Red              | Bootloader, initialization, configuration, startup until ready to switch on or error |
| Status | ON               |  |
| Color  | -                | Reset or no voltage  |
| Status | OFF              |  |

Safety function S2

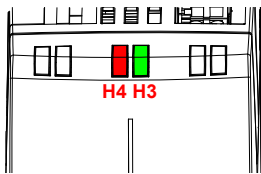

| LED    | H4            | H3               | Description   |
|--------|---------------|------------------|---|
| Color  | Red           | Green            | Startup   |
| Status | ON            | ON               |   |
| Color  | -             | Green            | STO is not activated.   |
| Status | OFF           | ON               |   |
| Color  | Red           | Green            | STO is not active (yet). The safety function should be designed as an error response. |
| Status | Flashing fast | ON               |   |
| Color  | -             | Green            | STO is active. Waiting for confirmation of the restart.                               |
| Status | OFF           | Flashing fast    |   |
| Color  | -             | Green            | STO is active.  |
| Status | OFF           | Flashing at 1 Hz |   |

| LED           | H4                | H3               | Description  |
|---------------|-------------------|------------------|--|
| <b>Color</b>  | Red               | -                | Error that cannot be acknowledged (safe state)   |
| <b>Status</b> | ON                | OFF              |  |
| <b>Color</b>  | -                 | -                | Reset or no voltage  |
| <b>Status</b> | OFF               | OFF              |  |
| <b>Color</b>  | Red               | -                | STO is active. Safety function as error response is to be (or was) executed. Expecting error acknowledgment. |
| <b>Status</b> | Flashing fast     | OFF              |  |
| <b>Color</b>  | Red               | -                | Waiting for error acknowledgment (safe state).   |
| <b>Status</b> | Flashing fast     | OFF              |  |
| <b>Color</b>  | Red               | Green            | Waiting for initialization of the safe encoders and FSoE communication.                                      |
| <b>Status</b> | Lights up briefly | Flashing at 1 Hz |  |

### 3.4 Nameplate

#### Main Nameplate

The main nameplate is located on the right side of the housing.

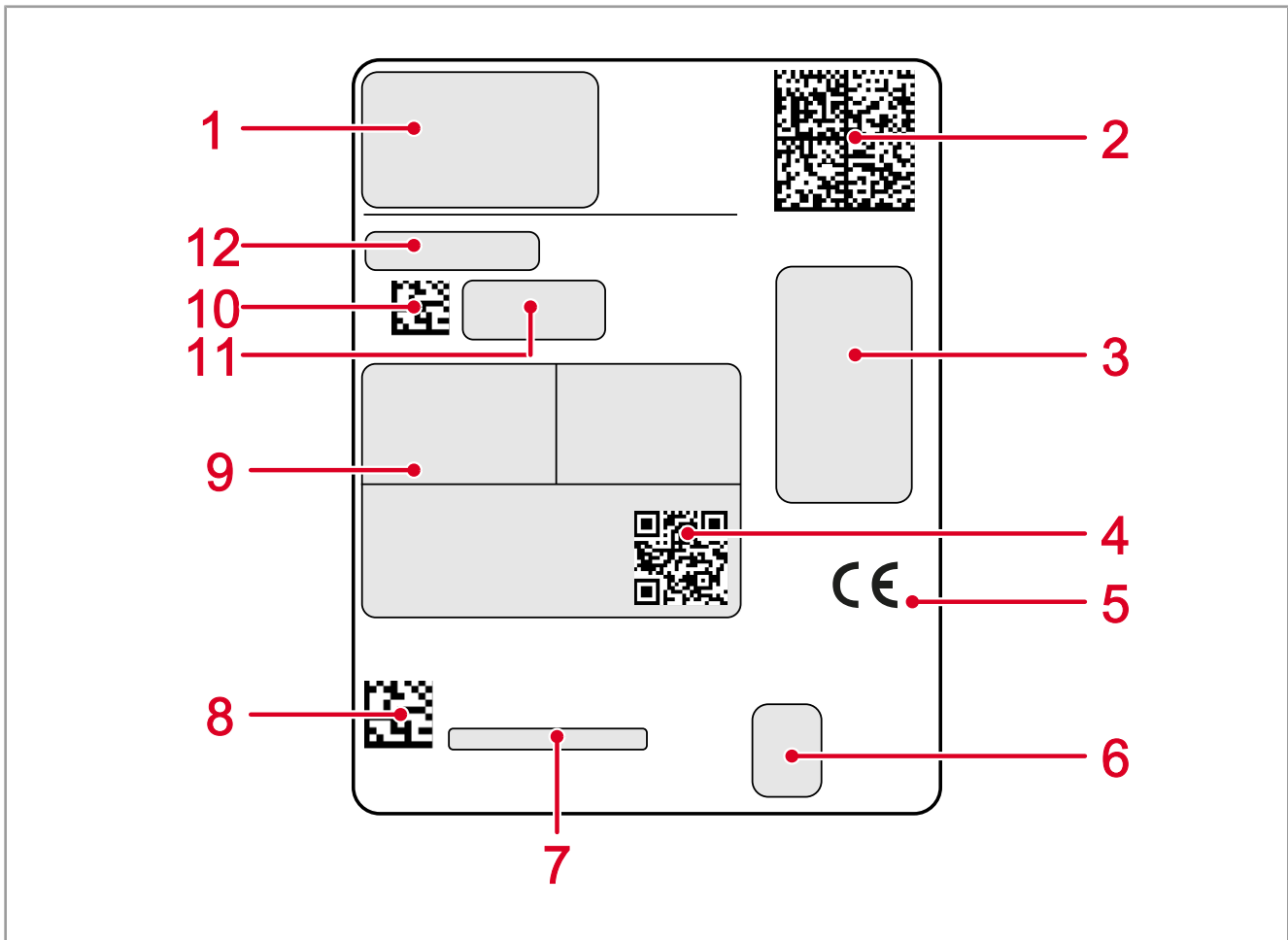

Fig. 5: Main Nameplate

|    |   |
|----|---|
| 1  | Company logo and address                                |
| 2  | Scan - Order number, serial number, and various details |
| 3  | UL certification  |
| 4  | Scan link to the download area                          |
| 5  | Certification mark                                      |
| 6  | Mandatory sign  |
| 7  | Serial number   |
| 8  | Scan - Serial Number                                    |
| 9  | Various details   |
| 10 | Scan - Item Number                                      |
| 11 | Item number   |
| 12 | Order code  |

### More labels

Additional labels are located on the JM-2203 / JM-2403 under the lower front cover:

- Label with serial number and order code on the front. The **order code** [▶ 22] also indicates the encoder configuration.



- **Security labels** [▶ 13] on the front and included
- Label with **Connection Instructions** [▶ 43] on the inside of the lower front cover

## 3.5 Scope of delivery

| Scope of delivery  | Item number          | Quantity    |
|--|----------------------|-------------|
| JM-2203 / JM-2403  | Depending on options | 1           |
| USB stick with complete documentation                    | 60888000             | 1 per order |
| Fitting panel (top)                                      | 60885886             | 1           |
| Fitting panel (bottom)                                   | 60885603             | 1           |
| Fastening bracket for motor cable with shielding bracket | 60886090             | 1           |
| Power-level terminal connector set, single-axis, size 1  | 60886080             | 1           |
| I/O and S1 connector set, single-axis                    | 60886077             | 1           |
| <b>OR</b>  |                      |             |
| I/O and S2 connector set, single-axis                    | 60886078             | 1           |
| Warning Label  | 60888987             | 1           |

### 3.6 Encoder options

The JM-2203 / JM-2403 has 2 plug-in slots for encoder options. For the encoder options your device supports, refer to the nameplate and the [order code \[▶ 23\]](#).

#### Plug-in slots

The order of the encoders on the hardware is always from right to left.

#### NOTICE



**Conversions to the device may only be carried out by Bucher Automation AG.**

The installed encoder options have a safety seal.

- ▶ Send the device in to Bucher Automation AG if you want to convert from –S1 to –S2 or another encoder placement.



Fig. 6: Example of placement -S2

#### Encoder options

| Encoder option | Description                | Motor encoder | Additional encoder | Cable technology |
|----------------|----------------------------|---------------|--------------------|------------------|
| JM-2000-R      | Resolver                   | X             |                    | 2                |
| JM-2000-H      | HIPERFACE DSL®             | X             |                    | 1                |
| JM-2000-A      | HIPERFACE® analog / SinCos | X             | X                  | 2                |
| JM-2000-E6     | EnDat® 2.2                 | X             | X                  | 2                |
| JM-2000-I      | Incremental encoder        |               | X                  | 2                |
| JM-2000-S2R    | Safe resolver              | X             |                    | 2                |

#### Examples

- **–S1R** = Resolver without additional encoder
- **–S1RA** = Resolver with analog additional encoder

#### See also

- 📄 [Order code \[▶ 23\]](#)

### 3.6.1 Order code

| JetMove 2000                               |  | PC | Module |   |   |    |   | Options |    |   |   |   |   |   |   |   |   |   |
|--|--|----|--------|---|---|----|---|---------|----|---|---|---|---|---|---|---|---|---|
| Order code                                 | JM   | -  | x      | 2 | 4 | 03 | x | -       | S1 | R | R | I | I | I | I | I | I | I |
| <b>Product class</b>                       | JM = JetMove   |    |        |   |   |    |   |         |    |   |   |   |   |   |   |   |   |   |
| <b>Module</b>                              |  |    |        |   |   |    |   |         |    |   |   |   |   |   |   |   |   |   |
| <b>Configuration (optional)</b>            | _ = Single-drive (single axis)<br>D = Double-drive (e.g. 2 x 3 A rated current for 2 axes per drive module)  |    |        |   |   |    |   |         |    |   |   |   |   |   |   |   |   |   |
| <b>Model series</b>                        | 2 = Series 2000  |    |        |   |   |    |   |         |    |   |   |   |   |   |   |   |   |   |
| <b>Supply voltage</b>                      | 2 = AC 230 V<br>4 = AC 400 V ... 480 V   |    |        |   |   |    |   |         |    |   |   |   |   |   |   |   |   |   |
| <b>Performance class</b>                   | 01 ... 999 = Rated current in Ampere   |    |        |   |   |    |   |         |    |   |   |   |   |   |   |   |   |   |
| <b>Hardware redesign of a model series</b> | B = 1 <sup>st</sup> Redesign (new item number)   |    |        |   |   |    |   |         |    |   |   |   |   |   |   |   |   |   |
| <b>Options</b>                             |  |    |        |   |   |    |   |         |    |   |   |   |   |   |   |   |   |   |
| <b>Safety technology</b>                   | S1 = STO (save torque-off) + SBC (safe brake control)<br>S2 = Extended functional safety (e.g. SLS, SLT, SLP, ...); FSoE slave with S2R or S2H safe encoders   |    |        |   |   |    |   |         |    |   |   |   |   |   |   |   |   |   |
| <b>Safe encoders</b>                       | S2R = Safe resolver<br>S2H = HIPERFACE DSL®, 2-wire  |    |        |   |   |    |   |         |    |   |   |   |   |   |   |   |   |   |
| <b>Non-safe encoders</b>                   | R = Analog resolver, 8-wire, including motor temperature sensor<br>H = Digital HIPERFACE DSL® encoder, 2-wire, 1-cable technology, digital recording of the motor temperature<br>A = Analog absolute encoder (HIPERFACE®, SinCos, 1Vss, SSI), 10-wire including power supply and motor temperature sensor<br>E6 = Digital EnDat® 2.2 encoder, 6-wire incl. power supply, digital recording of the motor temperature<br>I = RS-422 incremental encoder (8-wire, of which 2 wires for DC 5 V supply) |    |        |   |   |    |   |         |    |   |   |   |   |   |   |   |   |   |
| <b>Communication interface</b>             | _ = EtherCAT® (default)  |    |        |   |   |    |   |         |    |   |   |   |   |   |   |   |   |   |
| <b>Technology (optional)</b>               |  |    |        |   |   |    |   |         |    |   |   |   |   |   |   |   |   |   |
| <b>Brake resistor (optional)</b>           | _ = Without internal brake resistor. Requires external brake resistor.<br>R1 = Assembled with internal brake resistor.   |    |        |   |   |    |   |         |    |   |   |   |   |   |   |   |   |   |
| <b>Housing cooling scheme (optional)</b>   | _ = Air cooling (default)  |    |        |   |   |    |   |         |    |   |   |   |   |   |   |   |   |   |
| <b>Feature package</b>                     | _ = <b>Move</b> : Position feedback control or speed control incl. encoder feedback (default)  |    |        |   |   |    |   |         |    |   |   |   |   |   |   |   |   |   |
| <b>Protective coating</b>                  | _ = No protective coating (default)  |    |        |   |   |    |   |         |    |   |   |   |   |   |   |   |   |   |

**JetMove 2000**

|            | PC | Module |   |   |   |    |   | Options |       |    |    |    |    |    |    |    |
|------------|----|--------|---|---|---|----|---|---------|-------|----|----|----|----|----|----|----|
| Order code | JM | -      | x | 2 | 4 | 03 | x | -       | S1RRI | Ix | Tx | Rx | Cx | Fx | Lx | Ax |

**Hardware revision**

A0 = Hardware revision 0

A1 = Hardware revision 1

... ..

# 4 Technical Specifications

This chapter contains the electrical and mechanical specifications, as well as the operating data, for the JM-2203 / JM-2403 device.

## 4.1 Dimensions

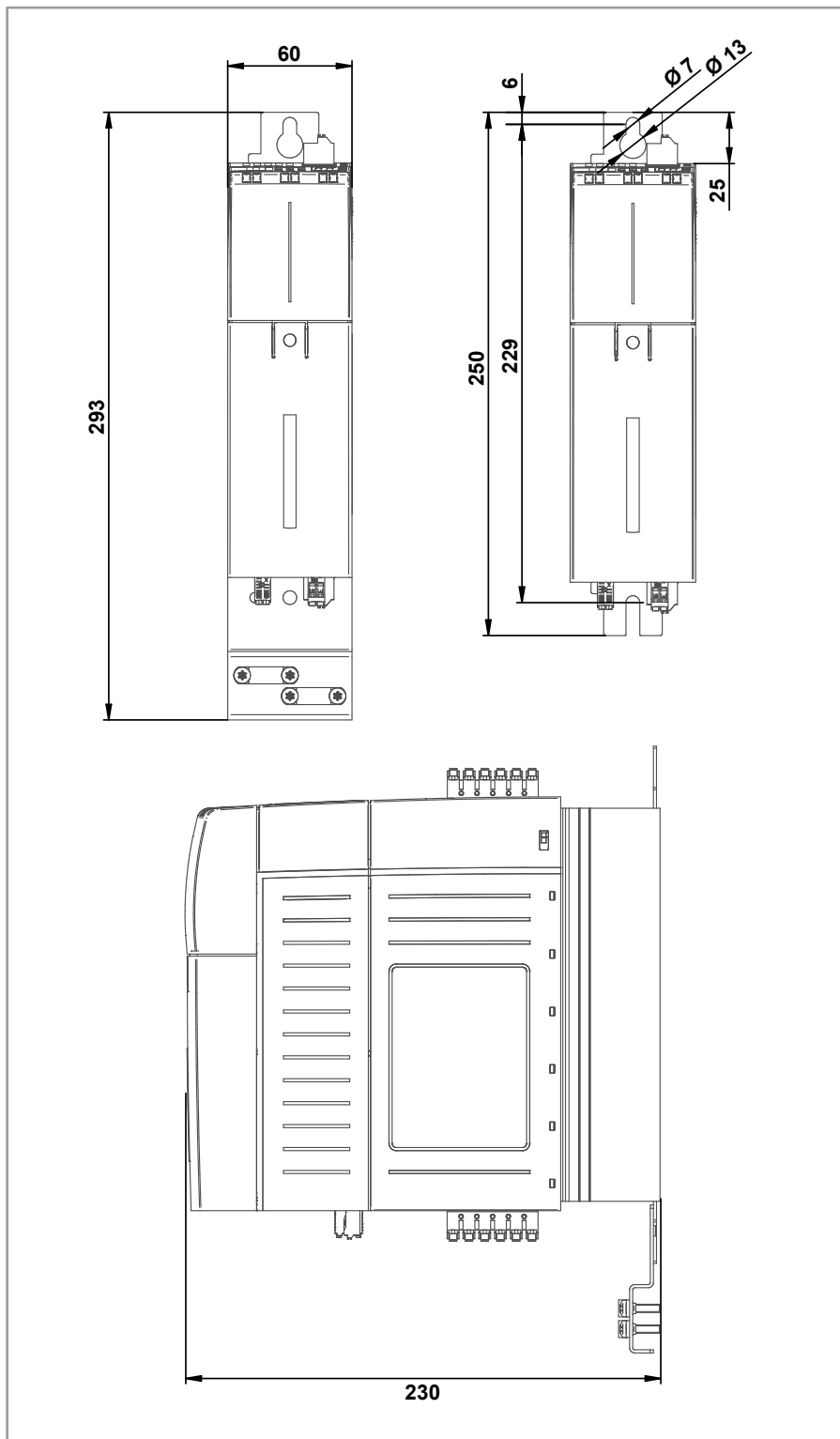

Fig. 7: Dimension in mm

 **Info**
**CAD data**

For CAD data go to [www.bucherautomation.com](http://www.bucherautomation.com) and navigate to the product page JM-2203 / JM-2403 > Downloads.

## 4.2 Mechanical specifications

| Parameter            | Description     |
|----------------------|-----------------|
| Weight approx.       | 1650 g          |
| Type of installation | vertical        |
| Protection class     | IP20 (EN 60529) |

Tab. 1: Technical data – mechanical properties

## 4.3 Output motor side

**NOTICE!** The device is designed to be used with copper conductors sized according to the 65 °C or 75 °C temperature tables.

Please refer to the information in the section [Derating](#) [▶ 30].

| Parameter                     | JM-2203                  | JM-2403               |
|-------------------------------|--------------------------|-----------------------|
| Output voltage                | 0 V ... 230 V            | 0 V ... 400 V (480 V) |
| Output current                | 3 A                      | 3 A                   |
| Rotary field frequency        | 0 Hz ... 599 Hz          | 0 Hz ... 599 Hz       |
| Recommended motor shaft power | 1ph 0,55 kW / 3ph 1,1 kW | 1,5 kW                |
| Short-time overcurrent (3 s)  | 9 A                      | 9 A                   |
| Switching frequency           | 8 kHz, 16 kHz            | 8 kHz, 16 kHz         |
| Protection                    | IP20                     | IP20                  |
| Long-time overcurrent (60 s)  | 6 A                      | 6 A                   |

Tab. 2: Technical Specifications – Motor-Side Output

### 4.3.1 External braking resistor

**NOTICE!** When using an external braking resistor, the values in the following table must be strictly observed.

| Parameter                        | JM-2203 | JM-2403 |
|----------------------------------|---------|---------|
| Internal braking power P(BR)     | 70 W    | 70 W    |
| Minimum braking resistance R(BR) | 47 Ω    | 100 Ω   |
| Power at minimum resistance      | 3.1 kW  | 5.8 kW  |
| Rated braking resistance         | 100 Ω   | 330 Ω   |
| Power at rated resistance        | 1.5 kW  | 1.8 kW  |

Tab. 3: External braking resistor

## 4.4 Input mains side

**NOTICE!** The device is designed to be used with copper conductors sized according to the 65 °C or 75 °C temperature tables.

**NOTICE!** The device must only be operated on a three-phase star-connected system in which no phase is directly grounded and the voltage between phase and ground does not exceed 277 V.

| Parameter                       | JM-2203                        | JM-2403                       |
|---------------------------------|--------------------------------|-------------------------------|
| Mains current                   | 1-phase: 7,1 A; 3-phase: 3,3 A | 3-phase: 3,3 A                |
| Fuse type gRL(gS) 400 V IEC     | 6 A                            | 6 A                           |
| Mains frequency                 | 50 Hz / 60 Hz                  | 50 Hz / 60 Hz                 |
| Mains frequency operating range | fLN ±10 %                      | fLN ±10 %                     |
| Mains voltage                   | 230 V                          | 400 V / (480 V)               |
| Mains voltage operating range   | 200 V - 15 % ... 240 V + 10 %  | 380 V - 15 % ... 480 V + 10 % |
| DC input voltage                | ULN * 1,41                     | ULN * 1,41                    |

**Tab. 4:** Technical data – mains-side input

### 4.4.1 Fuse types for UL applications

| Device           | 1-phase   | 3-phase  |
|------------------|-----------|----------|
| JM-2203, JM-2403 | FWP10A14F | FWP5A14F |

**Tab. 5:** Eaton Individual circuit breakers

## 4.5 Ports and interfaces

### DC 24 V voltage supply (X12)

| Parameter              | Description   |   |
|------------------------|---|---|
| Input voltage          | 20.4 V ... 28.8 V (-15 % / +20 %)   |   |
| Nominal input current  | <b>Safety function S1</b>   | <b>Safety function S2</b>                       |
|                        | 2.80 A max  | 3.65 A max                                      |
|                        | Of which 2.0 A for motor holding brake  |   |
| Peak switching current | Typical < 8 A   |   |
| Peak power             | <b>Logic section</b>  | <b>incl. motor holding brake and S2 outputs</b> |
|                        | 19.5 W  | 101.5 W   |
| External fusing        | Using standard fusing elements for nominal current, characteristic: slow-blow |   |
| Safety                 | Safety extra-low voltage (SELV) to DIN EN 61800-5-1                           |   |
| Max. line length       | ≤ 30 m  |   |

Tab. 6: Technical data – DC 24 V voltage supply

### Activation of motor holding brake (X21)

| Parameter      | Description |
|----------------|-------------|
| Output voltage | DC 24 V     |
| Output current | 2 A         |

Tab. 7: Technical data – activation of motor holding brake

### Digital inputs (X210)

| Parameter        | Description                    |
|------------------|--------------------------------|
| $U_{max}$        | 30 V, 10 mA at DC 24 V         |
| Input resistance | 2.3 k $\Omega$                 |
| PLC-compatible   | Yes                            |
| Response time    | approx. 3 ms                   |
| Low              | 0 V ... 3 V                    |
| High             | 12 V ... 30 V                  |
| Type             | 24 V, type 3 to DIN EN 61131-2 |

Tab. 8: Technical data – digital inputs

**EtherCAT® interface (X212)**

| Parameter       | Description |
|-----------------|-------------|
| Terminal type   | RJ45 socket |
| Port count      | 2           |
| Bit rate        | 100 MBit/s  |
| Auto cross-over | Yes         |

**Tab. 9:** Technical data – EtherCAT® interface**4.6 Environmental conditions**

| Parameter                            | Description  |
|--------------------------------------|--|
| Operating temperature                | 0°C ... +55°C; at temperatures of 45°C or higher, a reduction in performance must be taken into account: -2.5%/K |
| Storage temperature                  | -25 °C ... +55 °C / -13 °F ... +131 °F   |
| Shipping temperature                 | -25 °C ... +70 °C / -13 °F ... +158 °F   |
| Rel. humidity                        | 5 % ... 85 %, non-condensing   |
| Elevation above sea level            | 0 m ... 4,000 m (reduced performance above 1,000 m)  |
| Mains-side surge protection category | Degree of 3 (III) DIN EN 61800-5- 1  |
| Environmental Specification          | Degree of 2 (II) DIN EN 61800-5- 1   |
| Installation location                | Contamination level 2 and no conductive condensation   |

**Tab. 10:** Technical data - Environmental conditions

## 4.7 External line filter

### Electrical properties

| Filter type   | $I_n$ /Ph | $I_{\text{overpow.}}$ /Ph   | Leakage current       | Power dissipation <sup>4)</sup> | Clamping area tightening torque                                   |
|---------------|-----------|---|-----------------------|---------------------------------|---|
| JEMC25.240-UR | 25 A      | 1.5 x $I_N$<br>for 60 s <sup>1)</sup>   | 24.5 mA <sup>3)</sup> | 4.8 W                           | 0.2 mm <sup>2</sup> ... 6.0 mm <sup>2</sup><br>1.5 Nm ... 1.8 Nm  |
| JEMC53.240-UR | 53 A      | 2 x $I_N$<br>for 10 s <sup>2)</sup><br>3 x $I_N$<br>for 100 ms<br><sup>2)</sup> |                       | 13.6 W                          | 0.5 mm <sup>2</sup> ... 16.0 mm <sup>2</sup><br>2.0 Nm ... 2.3 Nm |

Tab. 11: Technical data – external line filter

| Parameter             | Description   |
|-----------------------|---|
| Rated voltage         | 3 x 480 V, +10 %, 50/60 Hz <sup>4)</sup>                  |
| IEC climate category  | 25/105/21   |
| Standards             | IEC 60939-2 (2006-5), UL 508                              |
| Ambient temperature   | max. +45 °C (max. +55 °C, 1 % current derating per 1 °C)  |
| Installation altitude | max. 1,000 m (up to 2,000 m 1 % power decrease per 100 m) |
| Degree of protection  | IP20  |

1) Can be repeated after 30 min

2) Can be repeated after 6 min

3) rms value of the leakage currents to IEC 60939 (2009) at 50 Hz and rated voltage with 2 % asymmetry. The leakage current can be further increased by the device from which interference is being suppressed.

4) If the supply frequency = 60 Hz, the power loss is about 10 % higher!

## 4.8 Derating

This chapter deals with the power reduction (derating) of devices under certain environmental conditions. The influences on the output power must be taken into account in order to ensure safe operation of the device.

### Output current derating

The values are valid for a mains input voltage of 400 V.

| Switching frequency | @8 kHz | @16 kHz |
|---------------------|--------|---------|
| JM-2203             | 3 A    | 2.1 A   |
| JM-2403             | 3 A    | 2.1 A   |

Tab. 12: Output current derating depending on the switching frequency

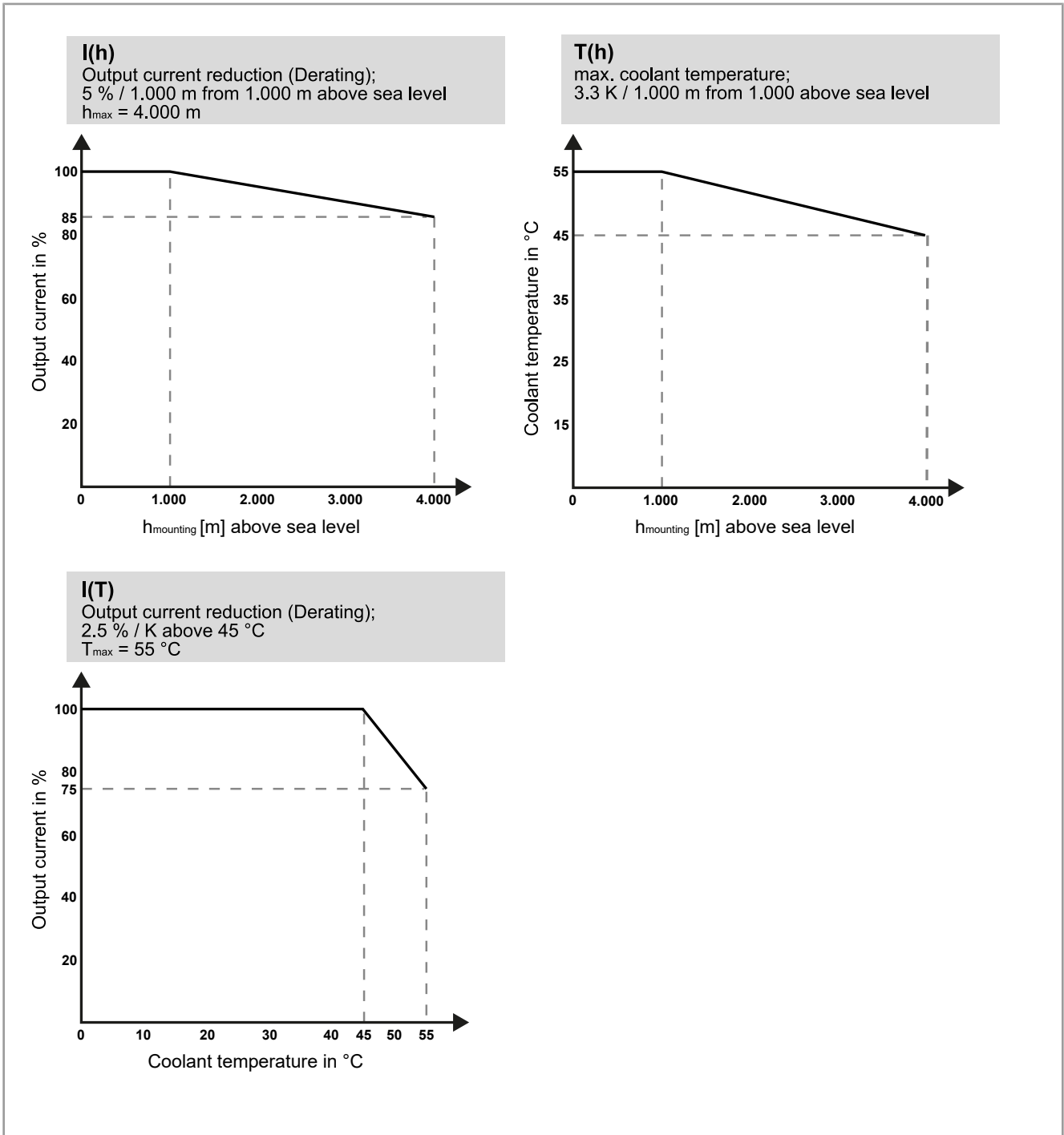

Fig. 8: Derating diagrams

## 5 Mechanical installation

This chapter describes how to install and remove the JM-2203 / JM-2403.

### ⚠ WARNING



#### Non-observance of safety instructions may result in injuries or physical damage

- ▶ Prior to assembling and installing the device, read and follow the safety precautions and restrictions of use as set out in the Safety chapter.
- ▶ Only authorized qualified personnel is allowed to perform any kind work on the device.

### NOTICE



#### Damaged devices

Damaged devices may cause considerable physical damage.

- ▶ Check the device for external damage and faulty connections.
- ▶ Ensure to install only fully functional devices.

### NOTICE



#### Usage of safety-relevant components

The JM-2203 / JM-2403 with -S1 option uses safety-relevant components that put extra requirements on the control cabinet housing.

- ▶ Install the JM-2203 / JM-2403 only in control cabinets with a degree of protection of IP54 or higher.

### NOTICE



#### Related documents

When installing and connecting the servo amplifiers within the axis system, it is essential to also follow the operating instructions for the other devices as well as the *Function Description Integrated Safety Function S1 - JM-2000 and JM-D2000*. You can find the documentation at [www.bucherautomation.com](http://www.bucherautomation.com) under *Product Page JM-2203 / JM-2403 > Downloads*.

## 5.1 Mounting the servo amplifier

Use the enclosed **mounting material** [▶ 67].

For the dimensions refer to the **Dimensions** [▶ 25] illustration.

### Sliding in the fitting panels

- ▶ Slide the fitting panels into the cooling ribs from above and below.

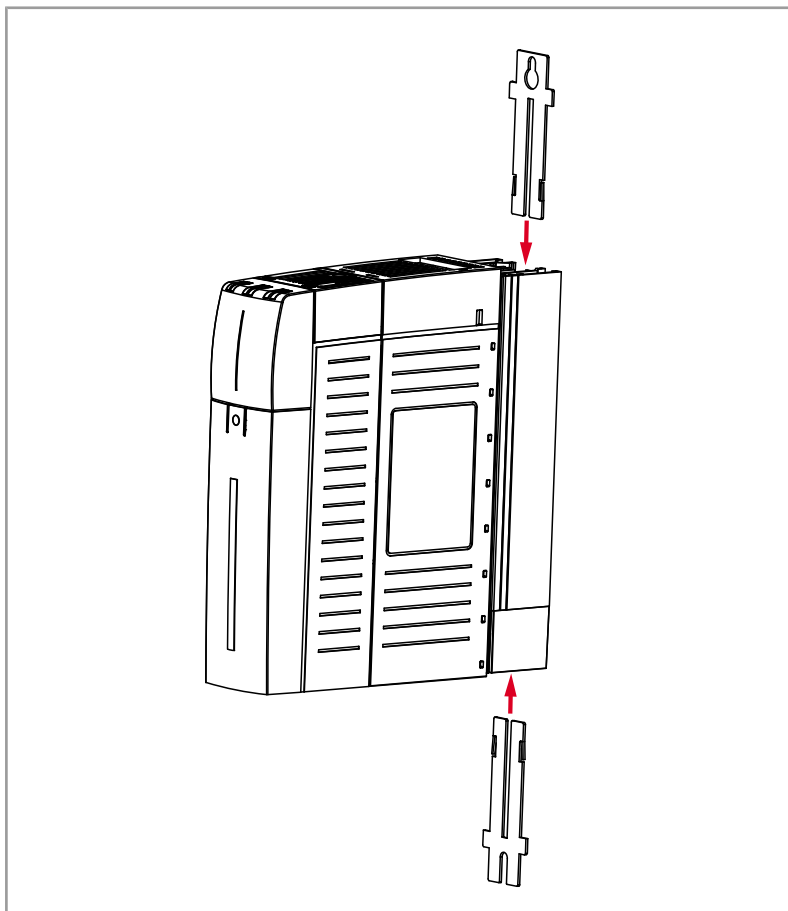

### Requirements for the installation location

- The mounting plate must be conductive.
- The degree of protection of the JM-2203 / JM-2403 is IP20. The JM-2203 / JM-2403 with -S1 option uses safety-relevant components that require them to be installed in control cabinets with a degree of protection of IP54 or higher.
- Pollution degree 2 without conductive condensation
- Avoid installation locations in the control cabinet where high temperatures occur.

### Distances

- Observe the minimum distances above and below the JM-2203 / JM-2403. No lateral distance from other devices is required.

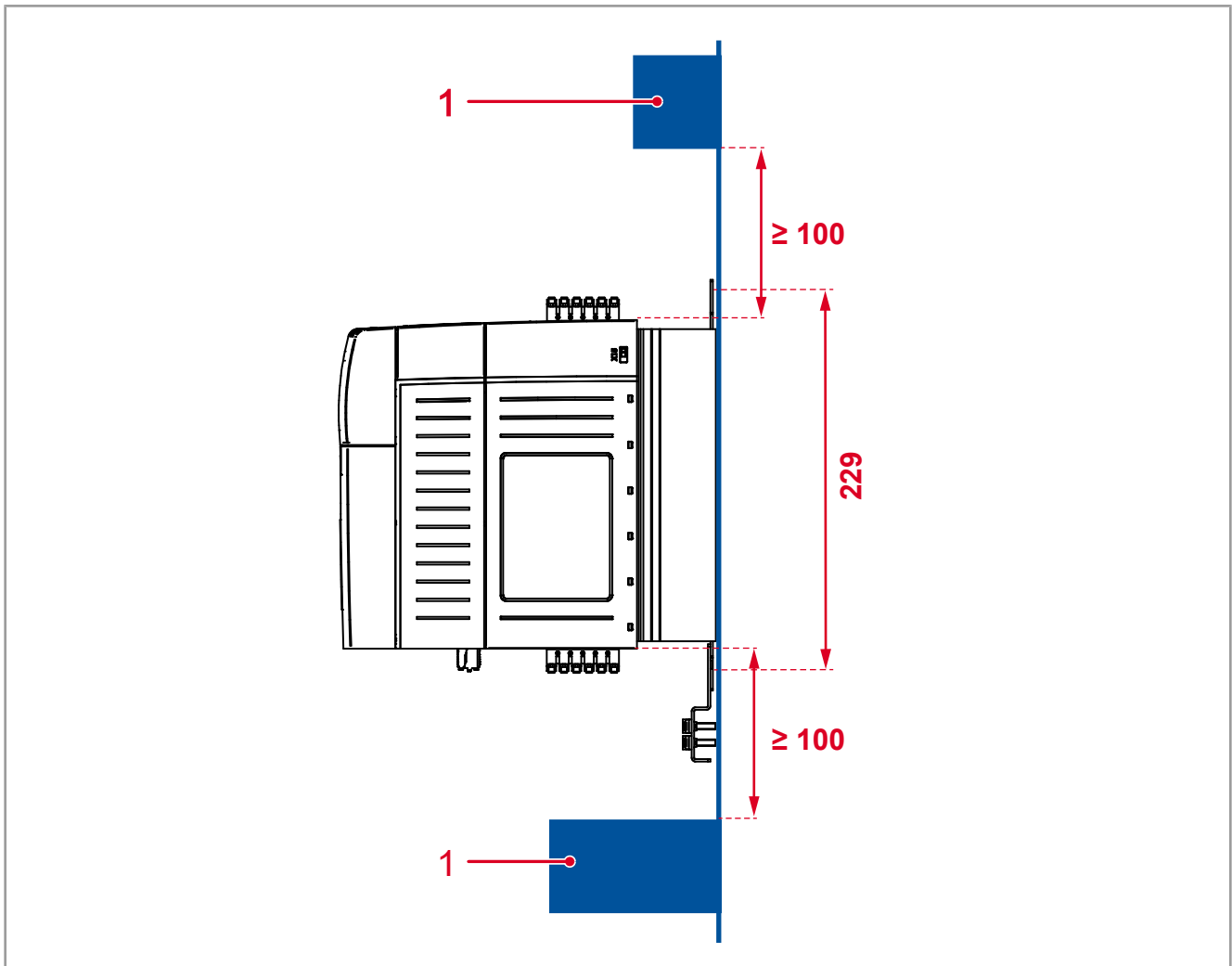

Fig. 9: Distances from surrounding parts in mm

|   |                                 |
|---|---------------------------------|
| 1 | Mounting plate with cable ducts |
|---|---------------------------------|

### Mechanical installation

#### **i** Info

#### Limited space conditions

The space for wiring may be restricted for wiring the JM-2203 / JM-2403 in mounted state. If necessary wire the upper and lower connections before you mount the device in the control cabinet ([Connections](#) ▶ 44).

Perform the following steps to install the JM-2203 / JM-2403:

1. Hold the JM-2203 / JM-2403 vertical on the mounting plate of the control cabinet.
2. Mark 2 points on the mounting plate for the mounting holes. Drill the holes and tap the threads.
3. Screw the upper fastening screw halfway into the thread.

4. Screw the shield bracket halfway into the thread with the lower fastening screw.

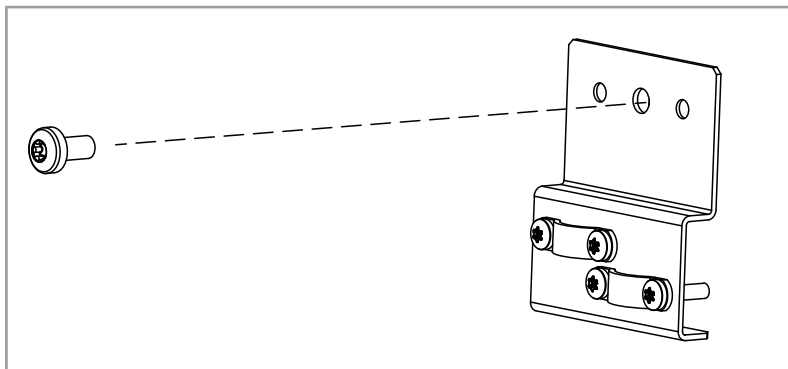

5. Set the lower fitting panel on the lower fastening screw.
6. Attach the upper fitting panel to the upper fastening screw.
7. Fix the two fastening screws in place.

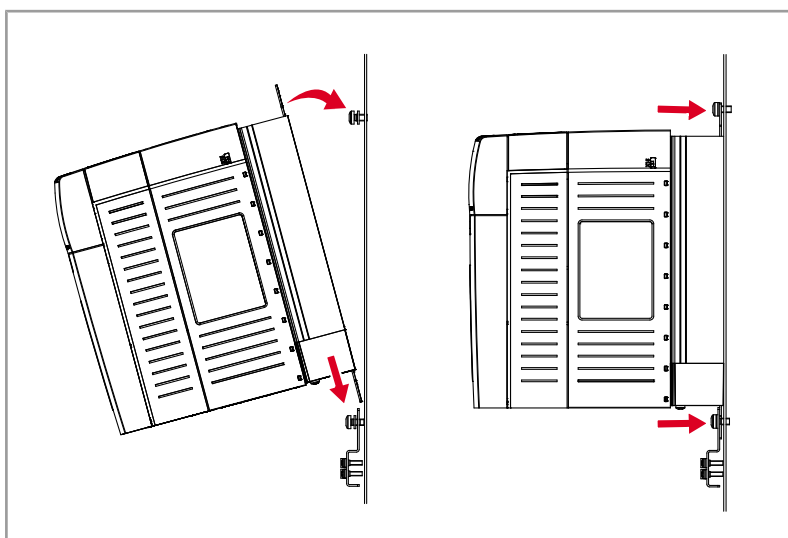

## 5.2 Removing the servo amplifier

To dismantle the JM-2203 / JM-2403, proceed as follows:

1. De-energize the JM-2203 / JM-2403.
2. Unscrew the 2 fastening screws halfway.
3. Slightly lift the Servoverstärker and remove it from the fastening screws.

### 5.3 Mounting the line filter

**Please note**

- The line filter must be designed to reduce any interference emitted by the JM-2203 / JM-2403 servo amplifier as required by the EMC Directive (see also [Line filter \[▶ 42\]](#)).
- Mount the line filter on a grounded mounting plate, preferably chromated or galvanized. Make sure to provide the largest surface possible for contact of the housing with the plate. You can achieve good surface contact with the threaded surface.
- In addition, the line filter should be grounded with a wide ground strap (length max. 300 mm).
- Mount the line filter in the immediate vicinity of the servo amplifier(s).
- Depending on the total output and total motor line length, several JetMoves can be connected to a central line filter in the servo amplifier control cabinet (see also [Line filter \[▶ 42\]](#)).

**Dimensions**

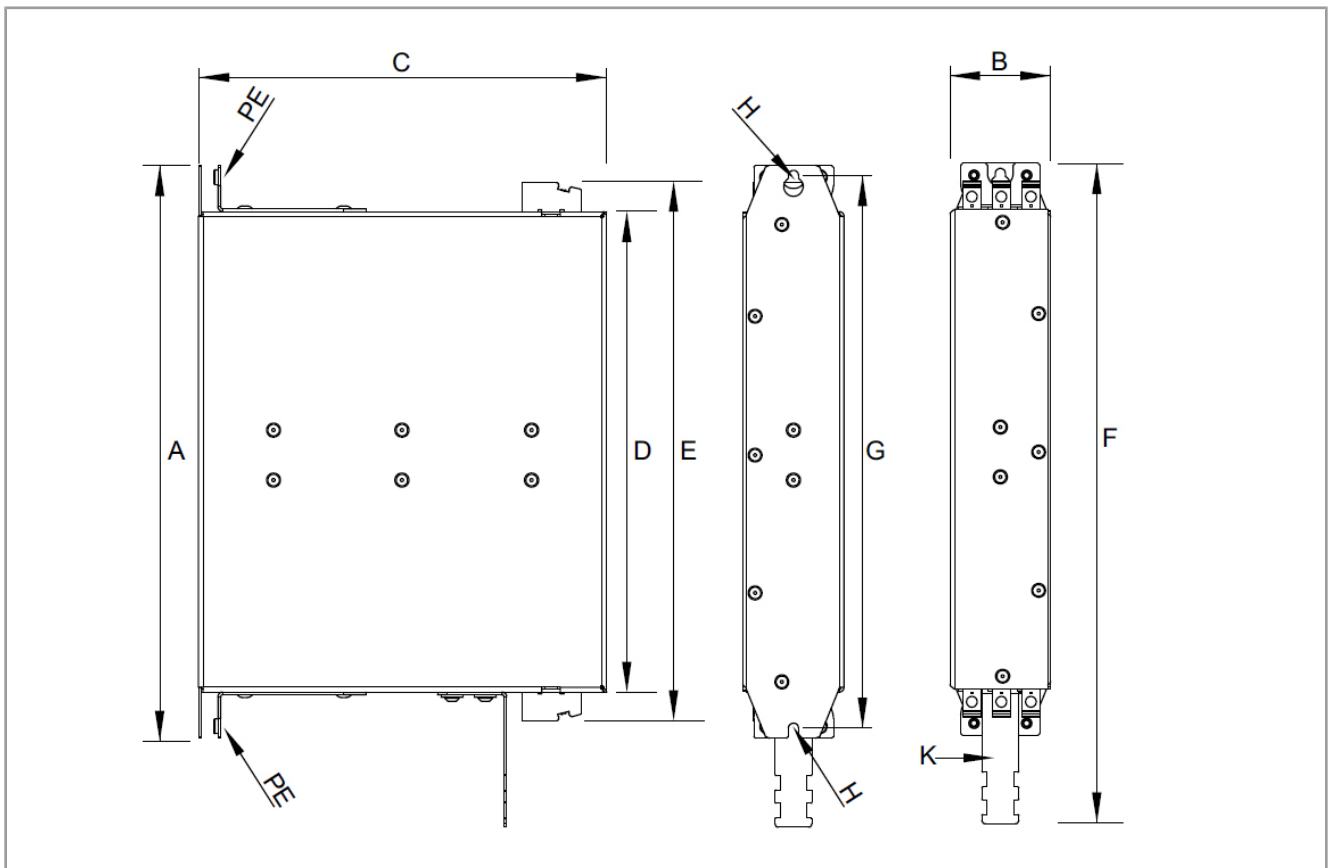

Fig. 10: Dimensions ext. line filter

| Dimensions |                            | JEMC25.240-UR | JEMC53.240-UR |
|------------|----------------------------|---------------|---------------|
| A          | Height                     | 310 mm        |               |
| B          | Width                      | 55 mm         |               |
| C          | Depth                      | 220 mm        |               |
| D          | Housing                    | 260 mm        |               |
| E          | Distance between terminals | 291 mm        | 324.6 mm      |
| F          | Total height               | 358 mm        | 365.3 mm      |

| Dimensions |                | JEMC25.240-UR | JEMC53.240-UR |
|------------|----------------|---------------|---------------|
| G          |                | 300 mm        |               |
| H          | Mounting holes | Ø 5.3 mm      |               |
| PE         |                | M4            |               |
| Weight     |                | 4.6 kg        | 4.8 kg        |

Tab. 13: Dimensions – external line filter

### Shield connecting bracket

## NOTICE



#### Mounting the shield connecting bracket

The shield connecting bracket (K) is designed to ensure contact with the cable shield.

- ▶ Mount the shield connecting bracket (K) on the line filter **before** you install the line filter.

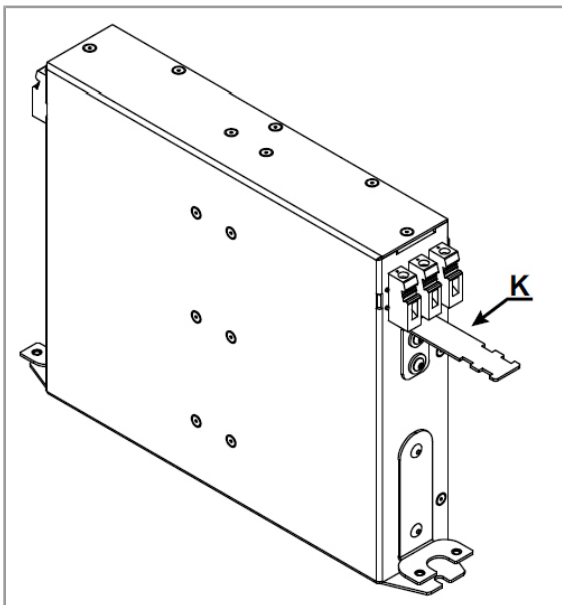

Fig. 11: Mounting the shield connecting bracket on the line filter

### Mechanical installation

1. Choose a suitable place for mounting the line filter. Note the bending radii of the connection cables as you do this.
2. Mark the position of the threaded holes on the mounting plate. Cut a thread in the mounting plate for each fastening screw and screw the fastening screws 2 revolutions into the threaded holes.
3. When using shielded cables, mount them to the shielding bracket (K) with shield clamps and fasten them onto the bottom of the line filter with the enclosed screws.
4. Attach the line filter to the fastening screws and tighten them down.

## 6 Electrical connection

### DANGER



#### Danger due to high electrical voltage

Touching live parts may result in death or severe injuries. Carry out the following steps before starting work to ensure safety:

- ▶ Prepare for shutting off the system. Inform everyone involved who will be affected by the process.
- ▶ Isolate the drive system from the power supply and secure it against being turned on again.
- ▶ Wait for the discharge time (approx. 3 minutes) and check all power connections to ensure they are at zero potential.
- ▶ Ground according to requirements.
- ▶ Cover over neighboring live parts.
- ▶ Ensure the drives cannot move.

### DANGER



#### Danger due to high operating voltage

The high operating voltage may cause serious injury, or death.

Please follow these rules throughout the **entire work process**.

- ▶ Do not remove any cover plates and keep all control cabinet doors closed during operation.
- ▶ Check that all live connections are protected against contact.
- ▶ Do not open the device.
- ▶ Never touch the device's power supply and DC link terminals (X1, X2, and, for the JM-D2000, X3 as well) while the device is in operation.

### DANGER



#### Danger due to high electrical voltage

According to EN 61800-5-1, connecting thermal sensors to the encoder port (extra-low voltage) within the motor requires double or reinforced insulation .

### WARNING



#### Non-observance of safety instructions may result in injuries or physical damage

- ▶ Prior to assembling and installing the device, read and follow the safety precautions and restrictions of use as set out in the Safety chapter.
- ▶ Only authorized qualified personnel is allowed to perform any kind work on the device.

**⚠ WARNING**

**The JM-2203 / JM-2403 generates leakage currents against PE.**

An upstream RCD type A must not be used, as pulsating and smooth DC fault currents can impair the function of the RCD.

- ▶ If an RCD is required, use either an RCD type B or an isolating transformer.

**NOTICE****Related documents**

When installing and connecting the servo amplifiers within the axis system, it is essential to also follow the operating instructions for the other devices as well as the *Function Description Integrated Safety Function S1 - JM-2000 and JM-D2000*. You can find the documentation at [www.bucherautomation.com](http://www.bucherautomation.com) under *Product Page JM-2203 / JM-2403 > Downloads*.

## 6.1 EMC-compliant installation

The noise immunity of a system is determined by its weakest component. Correct connections, lines and shielding are key factors. Follow the procedures described in this chapter.

**i Info****Further information**

For more information on system immunity to interference, please refer to Application Note 016 *EMC-Compliant Control Cabinet Installation* at [www.bucherautomation.com](http://www.bucherautomation.com).

The following basic rules apply to the installation of servo amplifiers:

- RoHS Directive 2011/65/EU
- EMC Directive 2014/30/EU
- Low Voltage Directive 2014/35/EU
- Machinery Directive 2006/42/EG

Protective earth conductor terminal

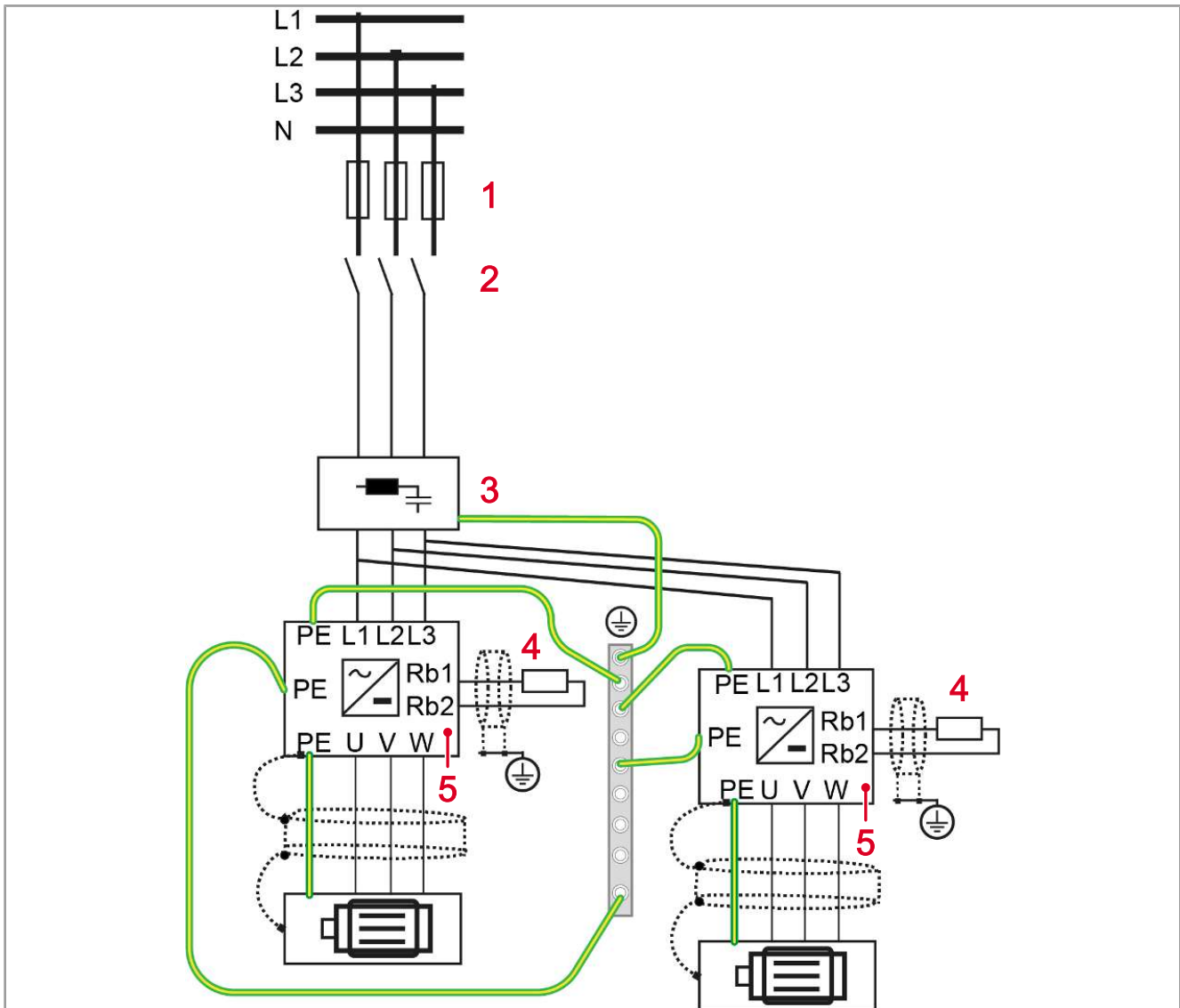

Fig. 12: Protective earth conductor terminal

|   |                                      |
|---|--------------------------------------|
| 1 | Fuse                                 |
| 2 | Line contactor                       |
| 3 | Line filter                          |
| 4 | External braking resistor (optional) |
| 5 | JM-2203 / JM-2403                    |

Grounding measures

- Mount the devices on a conductive, grounded mounting plate. The mounting plate must be connected to the control cabinet's central grounding busbar.
- Connect the PE cable with a cross-sectional area of at least 2.5 mm<sup>2</sup> to the PE terminal on the JM-2203 / JM-2403.
- Ground the shields on both sides.

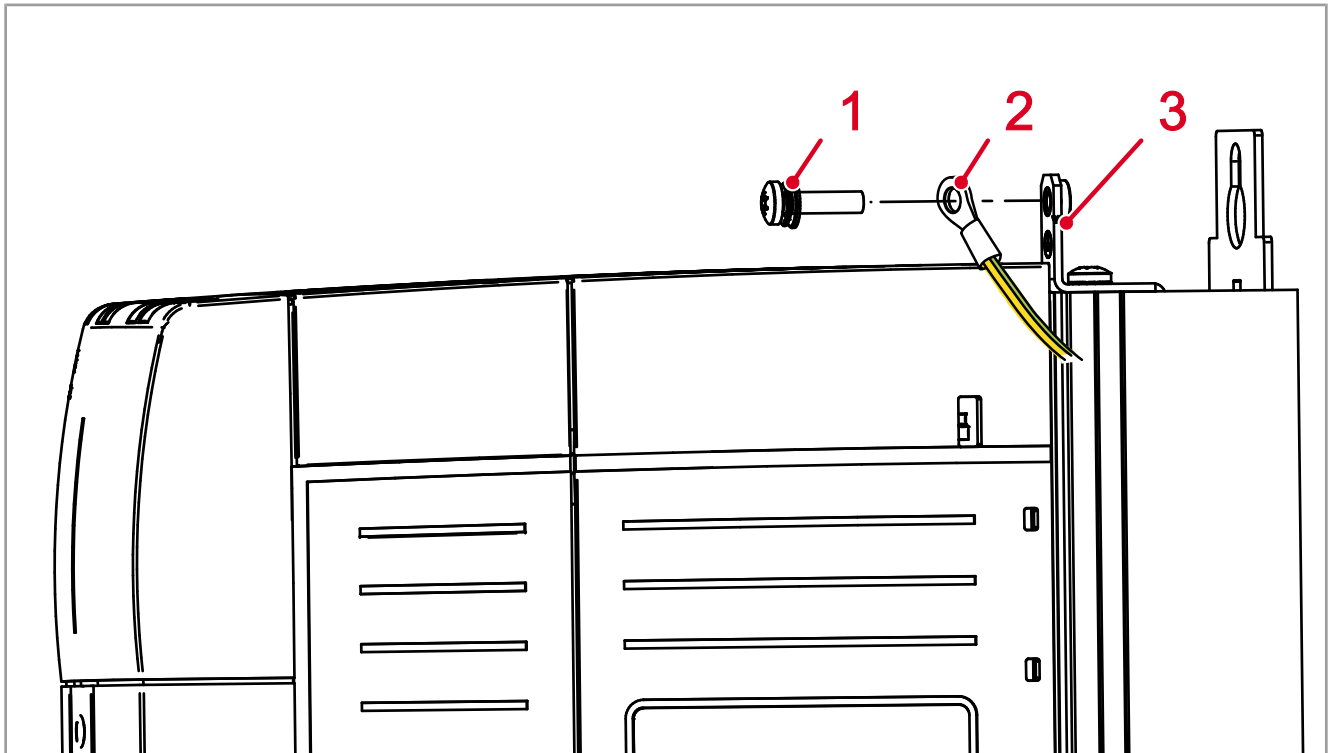

Fig. 13: Connection at the PE connector.

|   |  |
|---|--|
| 1 | Screw-and-washer assembly: Oval-head screw M4x12 Torx 8.8 acc. to DIN 6900 |
| 2 | Lug on PE cable  |
| 3 | PE angle on device   |

**Shielding measures**

- Use servo cables from Bucher Automation or equivalent servo cables.
- Use shielded encoder and motor cables (including a brake shield) that are suitable for use with servo motors (minimum shield coverage of 80%).
- Place the motor cable shields under the terminals of the shield bracket and against the housing of the M23 connector on the motor side.
- Use Sub-D connectors with a metallized housing and M3 metric screws.

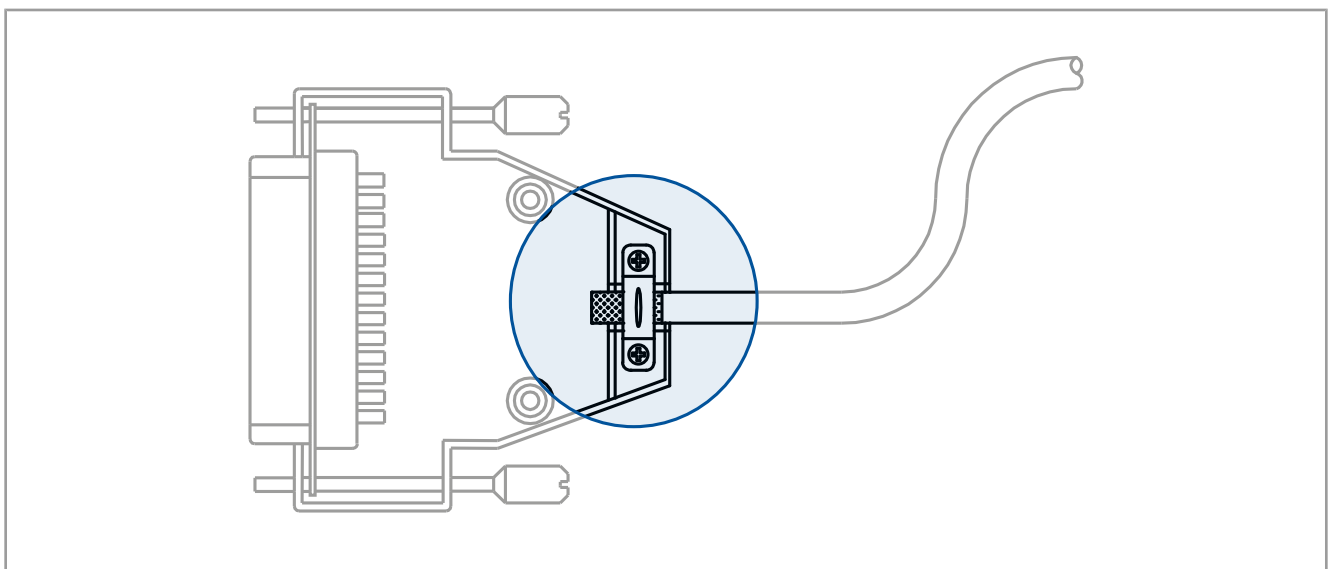

Fig. 14: EMC-compliant Sub-D shield connection

If you like more detailed information about installation, please contact the Bucher Automation hotline.

## See also

 [Technical Support \[► 66\]](#)

### 6.1.1 Line filter

#### Compliance with the EMC Directive

Commissioning, i.e., commencement of intended use is only permitted if the EMC Directive 2014/30/EU is complied with. Proof of compliance with the protection objectives required in the standard must be provided by the installer/operating company of a machine and/or system.

To ensure that line-borne interference emission remains limited to the permissible level, external line filters are available. The use of these line filters makes it possible to comply with EMC Directive 2014/30/EU under certain conditions:

- Public low-voltage network "First environment" (residential area C2)
- Industrial low-voltage network "Second environment" (industrial area C3)

#### Selecting line filters

The table below provides an initial estimate of which line filter can be expected to meet the given EMC requirements. This must be checked by the installer/operating company. Certain conditions require a different line filter. Demonstrate compliance with the EMC requirements metrologically.

| Power inlet current $I_{IN}$ |                        | $\leq 25 \text{ A}$ |               | $\leq 53 \text{ A}$ |               |
|------------------------------|------------------------|---------------------|---------------|---------------------|---------------|
| Total motor line length in m |                        | 0 ... 180           | 181 ... 600   | 0 ... 180           | 181 ... 600   |
| Category                     | Clock frequency in kHz |                     |               |                     |               |
| C2                           | 4                      | N/A                 | N/A           | N/A                 | N/A           |
|                              | 8                      | N/A                 | N/A           | N/A                 | N/A           |
|                              | 16                     | N/A                 | N/A           | N/A                 | N/A           |
| C3                           | 4                      | JEMC25.240-UR       | JEMC25.240-UR | JEMC53.240-UR       | JEMC53.240-UR |
|                              | 8                      | JEMC25.240-UR       | JEMC25.240-UR | JEMC53.240-UR       | JEMC53.240-UR |
|                              | 16                     | JEMC25.240-UR       | N/A           | JEMC53.240-UR       | N/A           |

**Tab. 14:** Suitable line filters

You can order suitable line filters separately as [accessories \[► 69\]](#).

## 6.2 Removing the lower front cover

To access the connections and encoder plug-in slots on the front of the device, the lower front cover must be removed. It is not necessary to remove the upper front cover.

### Procedure

1. Gently push down the depression in the middle of the lower front cover.
2. Pull the front cover down and off.

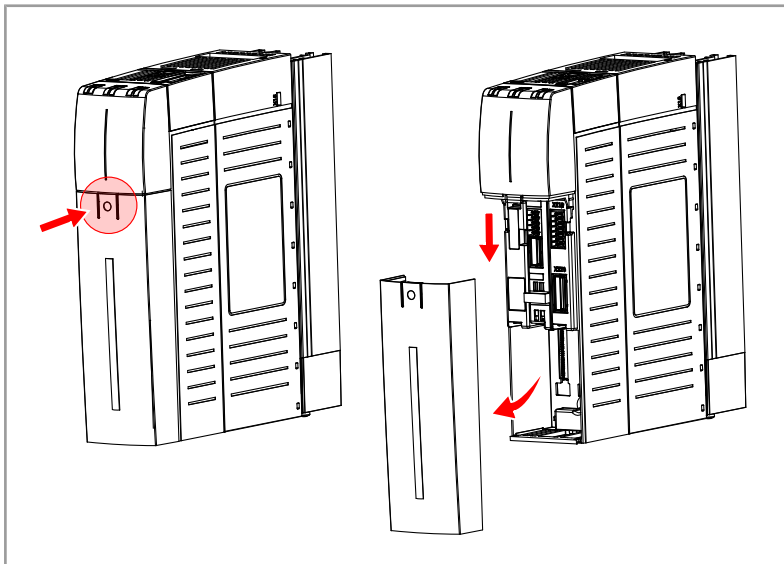

### Connection instructions

There is a label located on the inside of the lower front cover with connection instructions for the X210, X12, X21 and X22.

| BUCHER automation   |                     | JM-2000  |    |          |  |        |    |   |  |   |    |    |   |  |   |    |    |   |  |   |    |   |   |  |   |   |      |   |  |    |      |     |    |  |    |      |      |    |  |    |      |   |  |                   |                     |       |                     |       |    |     |    |     |  |
|---|---------------------|----------|----|----------|--|--------|----|---|--|---|----|----|---|--|---|----|----|---|--|---|----|---|---|--|---|---|------|---|--|----|------|-----|----|--|----|------|------|----|--|----|------|---|--|-------------------|---------------------|-------|---------------------|-------|----|-----|----|-----|--|
| <table border="1"> <thead> <tr> <th>Axis 2</th> <th></th> <th>X210 I/O</th> <th></th> <th>Axis 1</th> </tr> </thead> <tbody> <tr> <td>TP</td> <td>1</td> <td></td> <td>2</td> <td>TP</td> </tr> <tr> <td>L+</td> <td>3</td> <td></td> <td>4</td> <td>L+</td> </tr> <tr> <td>L-</td> <td>5</td> <td></td> <td>6</td> <td>L-</td> </tr> <tr> <td>R</td> <td>7</td> <td></td> <td>8</td> <td>R</td> </tr> <tr> <td>n.c.</td> <td>9</td> <td></td> <td>10</td> <td>n.c.</td> </tr> <tr> <td>GND</td> <td>11</td> <td></td> <td>12</td> <td>n.c.</td> </tr> <tr> <td>n.c.</td> <td>13</td> <td></td> <td>14</td> <td>n.c.</td> </tr> </tbody> </table> |                     | Axis 2   |    | X210 I/O |  | Axis 1 | TP | 1 |  | 2 | TP | L+ | 3 |  | 4 | L+ | L- | 5 |  | 6 | L- | R | 7 |  | 8 | R | n.c. | 9 |  | 10 | n.c. | GND | 11 |  | 12 | n.c. | n.c. | 13 |  | 14 | n.c. | <table border="1"> <thead> <tr> <th>X12 DC 24 V Input</th> <th>X21 Brake control 1</th> </tr> </thead> <tbody> <tr> <td>24Vin</td> <td>X22 Brake control 2</td> </tr> <tr> <td>24Vin</td> <td>B+</td> </tr> <tr> <td>GND</td> <td>B-</td> </tr> <tr> <td>GND</td> <td></td> </tr> </tbody> </table> |  | X12 DC 24 V Input | X21 Brake control 1 | 24Vin | X22 Brake control 2 | 24Vin | B+ | GND | B- | GND |  |
| Axis 2  |                     | X210 I/O |    | Axis 1   |  |        |    |   |  |   |    |    |   |  |   |    |    |   |  |   |    |   |   |  |   |   |      |   |  |    |      |     |    |  |    |      |      |    |  |    |      |   |  |                   |                     |       |                     |       |    |     |    |     |  |
| TP  | 1                   |          | 2  | TP       |  |        |    |   |  |   |    |    |   |  |   |    |    |   |  |   |    |   |   |  |   |   |      |   |  |    |      |     |    |  |    |      |      |    |  |    |      |   |  |                   |                     |       |                     |       |    |     |    |     |  |
| L+  | 3                   |          | 4  | L+       |  |        |    |   |  |   |    |    |   |  |   |    |    |   |  |   |    |   |   |  |   |   |      |   |  |    |      |     |    |  |    |      |      |    |  |    |      |   |  |                   |                     |       |                     |       |    |     |    |     |  |
| L-  | 5                   |          | 6  | L-       |  |        |    |   |  |   |    |    |   |  |   |    |    |   |  |   |    |   |   |  |   |   |      |   |  |    |      |     |    |  |    |      |      |    |  |    |      |   |  |                   |                     |       |                     |       |    |     |    |     |  |
| R   | 7                   |          | 8  | R        |  |        |    |   |  |   |    |    |   |  |   |    |    |   |  |   |    |   |   |  |   |   |      |   |  |    |      |     |    |  |    |      |      |    |  |    |      |   |  |                   |                     |       |                     |       |    |     |    |     |  |
| n.c.  | 9                   |          | 10 | n.c.     |  |        |    |   |  |   |    |    |   |  |   |    |    |   |  |   |    |   |   |  |   |   |      |   |  |    |      |     |    |  |    |      |      |    |  |    |      |   |  |                   |                     |       |                     |       |    |     |    |     |  |
| GND   | 11                  |          | 12 | n.c.     |  |        |    |   |  |   |    |    |   |  |   |    |    |   |  |   |    |   |   |  |   |   |      |   |  |    |      |     |    |  |    |      |      |    |  |    |      |   |  |                   |                     |       |                     |       |    |     |    |     |  |
| n.c.  | 13                  |          | 14 | n.c.     |  |        |    |   |  |   |    |    |   |  |   |    |    |   |  |   |    |   |   |  |   |   |      |   |  |    |      |     |    |  |    |      |      |    |  |    |      |   |  |                   |                     |       |                     |       |    |     |    |     |  |
| X12 DC 24 V Input   | X21 Brake control 1 |          |    |          |  |        |    |   |  |   |    |    |   |  |   |    |    |   |  |   |    |   |   |  |   |   |      |   |  |    |      |     |    |  |    |      |      |    |  |    |      |   |  |                   |                     |       |                     |       |    |     |    |     |  |
| 24Vin   | X22 Brake control 2 |          |    |          |  |        |    |   |  |   |    |    |   |  |   |    |    |   |  |   |    |   |   |  |   |   |      |   |  |    |      |     |    |  |    |      |      |    |  |    |      |   |  |                   |                     |       |                     |       |    |     |    |     |  |
| 24Vin   | B+                  |          |    |          |  |        |    |   |  |   |    |    |   |  |   |    |    |   |  |   |    |   |   |  |   |   |      |   |  |    |      |     |    |  |    |      |      |    |  |    |      |   |  |                   |                     |       |                     |       |    |     |    |     |  |
| GND   | B-                  |          |    |          |  |        |    |   |  |   |    |    |   |  |   |    |    |   |  |   |    |   |   |  |   |   |      |   |  |    |      |     |    |  |    |      |      |    |  |    |      |   |  |                   |                     |       |                     |       |    |     |    |     |  |
| GND   |                     |          |    |          |  |        |    |   |  |   |    |    |   |  |   |    |    |   |  |   |    |   |   |  |   |   |      |   |  |    |      |     |    |  |    |      |      |    |  |    |      |   |  |                   |                     |       |                     |       |    |     |    |     |  |
| <p>X1 Mains &amp; DC link<br/>                 X2 Motor 1 &amp; Brake resistor<br/>                 X3 Motor 2      Option axis 2</p>   |                     |          |    |          |  |        |    |   |  |   |    |    |   |  |   |    |    |   |  |   |    |   |   |  |   |   |      |   |  |    |      |     |    |  |    |      |      |    |  |    |      |   |  |                   |                     |       |                     |       |    |     |    |     |  |
| <p>Functional Safety: Please refer to Functional Safety Manual<br/>                 Power terminals : Please refer to User Manual</p>   |                     |          |    |          |  |        |    |   |  |   |    |    |   |  |   |    |    |   |  |   |    |   |   |  |   |   |      |   |  |    |      |     |    |  |    |      |      |    |  |    |      |   |  |                   |                     |       |                     |       |    |     |    |     |  |

Fig. 15: Connection instructions

### Spare parts

If the front cover is lost, it can be ordered as a [spare part \[▶ 67\]](#).

## 6.3 Connections

### Connections at the top and bottom

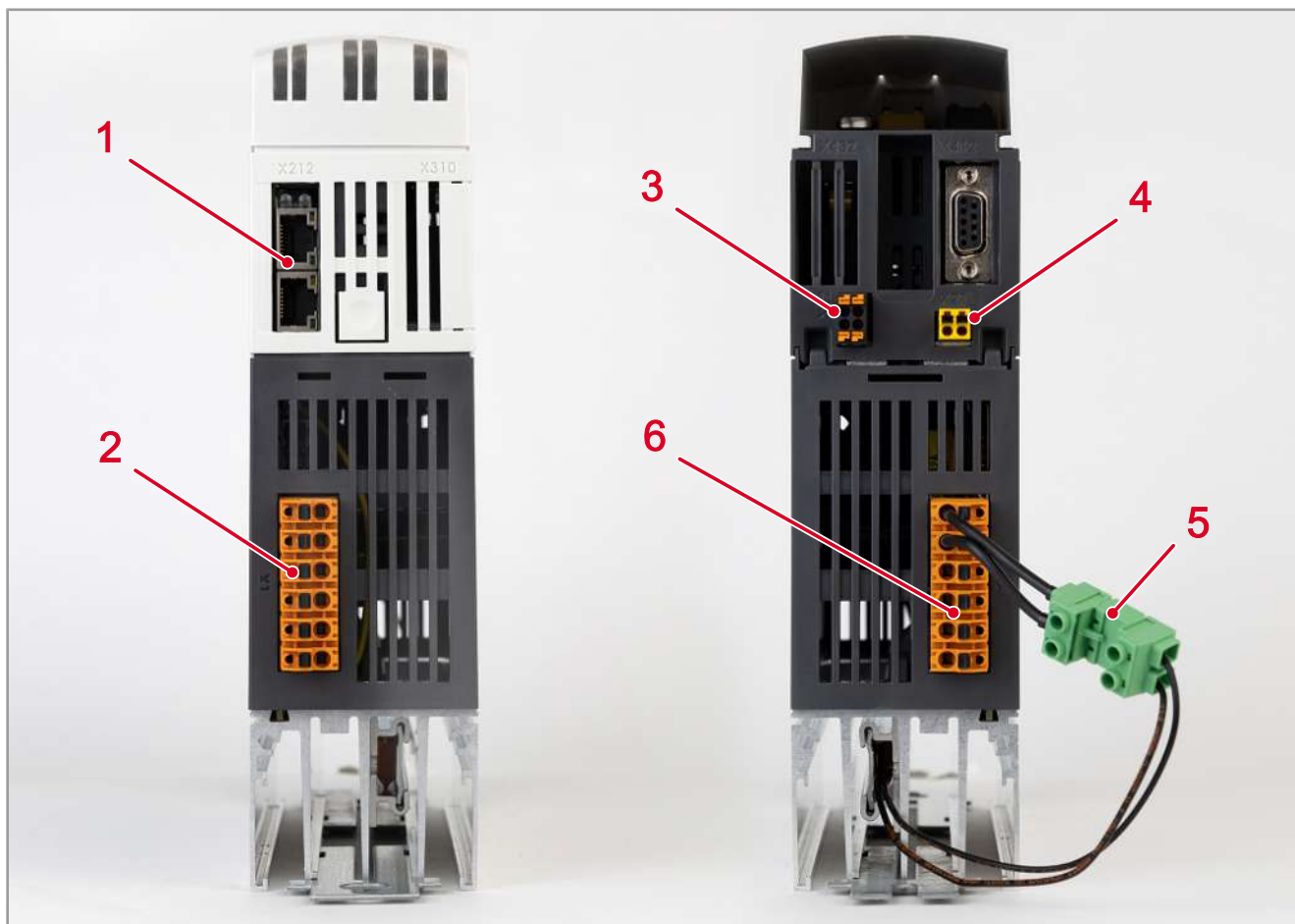

**Fig. 16:** Connection overview top and bottom

|   |  |
|---|--|
| 1 | Connection X212 – EtherCAT [▶ 46]                  |
| 2 | Connection X1 – AC voltage supply [▶ 47]           |
| 3 | Connection X12 – DC 24 V supply [▶ 49]             |
| 4 | Connection X21 – motor holding brake axis 1 [▶ 50] |
| 5 | 2-pin adapter plug [▶ 55]                          |
| 6 | Connection X2 – motor connection axis 1 [▶ 48]     |

### Connections at the front

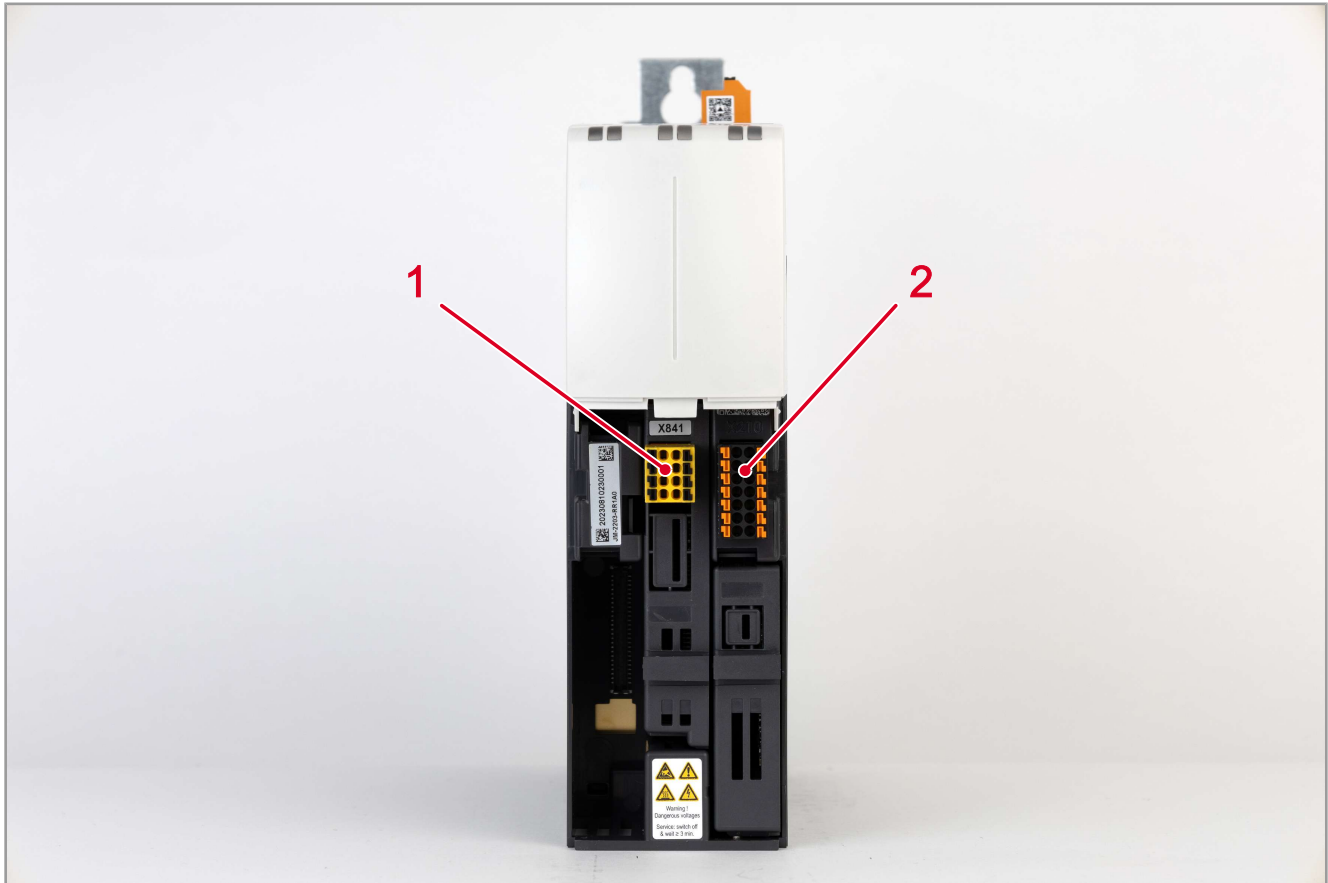

Fig. 17: Connection overview front

|   |                                     |
|---|-------------------------------------|
| 1 | Connection X841 - STO + SBC [▶ 51]  |
| 2 | Connection 210 - I/O signals [▶ 54] |

## NOTICE



### Property damage caused by incorrect sizing

Cables that are too small can cause overheating and thus pose a fire hazard.

- ▶ Use copper conductors rated for 65/75 °C for all power terminals.

### 6.3.1 Connection X212 – EtherCAT®

X212 connects to:

- EtherCAT® master or EtherCAT® slave

#### LEDs

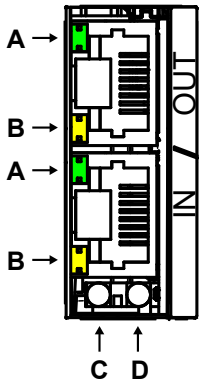

| RJ45 socket | Signal  | LED | Color  | Description                                |
|-------------|---------|-----|--------|--|
| OUT         | BUS OUT | A   | Green  | ACT: Data transmission                     |
|             |         | B   | Yellow | LINK: There is a connection to the network |
| IN          | BUS IN  | A   | Green  | ACT: Data transmission                     |
|             |         | B   | Yellow | LINK: There is a connection to the network |

Tab. 15: LEDs – EtherCAT® RJ45 socket

Fig. 18: Socket X212

| LED | Designation | Color | Description                    |
|-----|-------------|-------|--------------------------------|
| C   | RUN         | Green | EtherCAT®-communication active |
| D   | ERR         | Red   | Error EtherCAT® communication  |

Tab. 16: LEDs – EtherCAT® status

#### Cables

You can order suitable cables separately as [accessories](#) [▶ 69].

### 6.3.2 Connection X1 – AC voltage supply

Connect the following to X1:

- AC voltage supply

#### Pin assignment

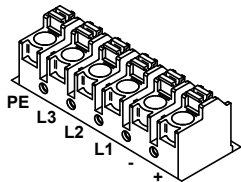

Fig. 19: Terminal X1, 6 pins

| Pin | 3-phase connection | 1-phase connection <sup>1)</sup> |
|-----|--------------------|----------------------------------|
| L1  | AC voltage phase 1 | AC voltage phase                 |
| L2  | AC voltage phase 2 | AC voltage neutral conductor     |
| L3  | AC voltage phase 3 | -                                |
| +   | DC link voltage +  |                                  |
| -   | DC link voltage -  |                                  |
| PE  | PE                 |                                  |

Tab. 17: Pin assignment – terminal X1

<sup>1)</sup> A 1-phase connection is only possible with JM-2000 devices powered by a 230 V supply, e.g. JM-2203.

#### 6-pin connector with push-in connection

| Parameter                                      | Description  | Standards   |
|--|--|-------------|
| Connection technique                           | Spring connection, push-in                                 |             |
| Type   | 6-pin, 7.62 mm pitch                                       |             |
| <b>Connectible conductors</b>                  |  |             |
| AWG  | 20 ... 12  |             |
| Terminal range                                 | 0.08 mm <sup>2</sup> ... 2.5 mm <sup>2</sup>               |             |
| <b>Specification without wire end ferrules</b> |  |             |
| Single-wire                                    | H05(07) V-U  |             |
|  | 0.5 mm <sup>2</sup> ... 1.5 mm <sup>2</sup>                |             |
| Multi-wire                                     | H05(07) V-K  |             |
|  | 0.5 mm <sup>2</sup> ... 2.5 mm <sup>2</sup>                |             |
| <b>Specification with wire end ferrules</b>    |  |             |
| Wire end ferrule without sleeve                | 0.5 mm <sup>2</sup> ... 2.5 mm <sup>2</sup>                | DIN 46228/1 |
| Wire end ferrule with sleeve                   | 0.5 mm <sup>2</sup> ... 2.5 mm <sup>2</sup>                | DIN 46228/4 |
| Contact length                                 | for wire end ferrule with sleeve up to 1.5 mm <sup>2</sup> |             |
|  | 8 mm ... 10 mm   |             |
|  | for wire end ferrule with sleeve up to 2.5 mm <sup>2</sup> |             |
|  | 10 mm ... 12 mm  |             |

Tab. 18: Connector specification, 6 pins, push-in connection

### 6.3.3 Connection X2 – motor connection axis 1

Connect the following to X2:

- Motor for axis 1
- External braking resistor

#### Pin assignment

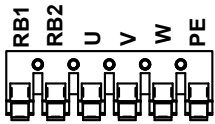

Fig. 20: Terminal X2, 6 pins

| Pin | Description                              |
|-----|--|
| RB1 | Braking resistance internal / external + |
| RB2 | Braking resistance internal / external - |
| U   | Motor cable U                            |
| V   | Motor cable V                            |
| W   | Motor cable W                            |
| PE  | Motor cable PE                           |

Tab. 19: Pin assignment- connection X2

#### 6-pin connector with push-in connection

| Parameter                                      | Description  | Standards   |
|--|--|-------------|
| Connection technique                           | Spring connection, push-in                                 |             |
| Type   | 6-pin, 7.62 mm pitch                                       |             |
| <b>Connectible conductors</b>                  |  |             |
| AWG  | 20 ... 12  |             |
| Terminal range                                 | 0.08 mm <sup>2</sup> ... 2.5 mm <sup>2</sup>               |             |
| <b>Specification without wire end ferrules</b> |  |             |
| Single-wire                                    | H05(07) V-U  |             |
|  | 0.5 mm <sup>2</sup> ... 1.5 mm <sup>2</sup>                |             |
| Multi-wire                                     | H05(07) V-K  |             |
|  | 0.5 mm <sup>2</sup> ... 2.5 mm <sup>2</sup>                |             |
| <b>Specification with wire end ferrules</b>    |  |             |
| Wire end ferrule without sleeve                | 0.5 mm <sup>2</sup> ... 2.5 mm <sup>2</sup>                | DIN 46228/1 |
| Wire end ferrule with sleeve                   | 0.5 mm <sup>2</sup> ... 2.5 mm <sup>2</sup>                | DIN 46228/4 |
| Contact length                                 | for wire end ferrule with sleeve up to 1.5 mm <sup>2</sup> |             |
|  | 8 mm ... 10 mm   |             |
|  | for wire end ferrule with sleeve up to 2.5 mm <sup>2</sup> |             |
|  | 10 mm ... 12 mm  |             |

Tab. 20: Connector specification, 6 pins, push-in connection

### 6.3.4 Connection X12 – DC 24 V supply

X12 connects to:

- DC 24 V supply

#### Pin assignment

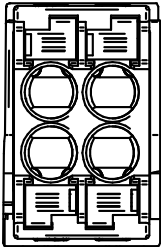

| X12   |     |
|-------|-----|
| 24Vin | GND |
| 24Vin | GND |

Tab. 21: Pin assignment – connection X12

Fig. 21: Terminal X12, 4 pins

- The 2 inputs for 24Vin are connected internally.
- The 2 GND inputs are connected internally.
- The second input can be used in each case to loop through additional drive controllers. The max. possible current load is 8 amps.  
The number of JetMove servo amplifiers for looping the DC 24 V voltage and GND through depends on the motor type (without or with brake) and the holding current of the motor brake. For larger motors with holding brake you can wire to max. one additional JetMove.

#### 4-pin connector with push-in connection

| Parameter  | Description                                   |
|--|---|
| Connection technique   | Spring connection, push-in                    |
| Type   | 4-pin, 3.5 mm pitch                           |
| Conductor cross-section, multi-wire                                      | 0.2 mm <sup>2</sup> ... 1.5 mm <sup>2</sup>   |
| Stripping length   | 9 mm ... 10 mm                                |
| Conductor cross-section, multi-wire with wire end ferrule with sleeve    | 0.25 mm <sup>2</sup> ... 0.75 mm <sup>2</sup> |
| Conductor cross-section, multi-wire with wire end ferrule without sleeve | 0.25 mm <sup>2</sup> ... 1.5 mm <sup>2</sup>  |
| Contact length   | 8 mm ... 10 mm                                |

Tab. 22: Connector specification, 4 pins, push-in connection

### 6.3.5 Connection X21 – motor holding brake axis 1

X21 connects to:

- Motor holding brake for axis 1

#### Pin assignment

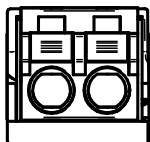

| X21 |    |
|-----|----|
| B+  | B- |

Tab. 23: Pin assignment – connection X21

Fig. 22: Terminal X21, 2 pins

#### 2-pin connector with push-in connection

| Parameter  | Description                                  |
|--|--|
| Connection technique   | Spring connection, push-in                   |
| Type   | 2-pin, 3.81 mm pitch                         |
| Conductor cross-section, multi-wire                                      | 0.2 mm <sup>2</sup> ... 1.5 mm <sup>2</sup>  |
| Stripping length   | 9 mm ... 10 mm                               |
| Conductor cross-section, multi-wire with wire end ferrule with sleeve    | 0.25 mm <sup>2</sup> ... 1.5 mm <sup>2</sup> |
| Conductor cross-section, multi-wire with wire end ferrule without sleeve | 0.25 mm <sup>2</sup> ... 1.5 mm <sup>2</sup> |
| Contact length   | 10 mm  |

Tab. 24: Connector specification, 2 pins, push-in connection

### 6.3.6 Connection X841 – STO + SBC [S1]

X841 connects to:

- STO for axis 1

## NOTICE



#### Related documents

When installing and connecting the servo amplifiers within the axis system, it is essential to also follow the operating instructions for the other devices as well as the *Function Description Integrated Safety Function S1 - JM-2000 and JM-D2000*. You can find the documentation at [www.bucherautomation.com](http://www.bucherautomation.com) under *Product Page JM-2203 / JM-2403 > Downloads*.

#### Pin assignment X841

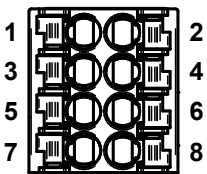

Fig. 23: Terminal X841, 8 pins

| Pin | Signal      | Description   |
|-----|-------------|---|
| 1   | AX1_STOA_In | STO input AX1 - requirement for pulse lock, channel A |
| 2   | AX1_STOB_In | STO input AX1 - requirement for pulse lock, channel B |
| 3   | GND_AX1     | Reference potential AX1                               |
| 4   | GND_AX1     | Reference potential AX1                               |
| 5   | AX1_SBCA_In | SBC input AX1 - requirement for safe brake, channel A |
| 6   | AX1_SBCB_In | SBC input AX1 - requirement for safe brake, channel B |
| 7   | n.c.        | n.c.  |
| 8   | n.c.        | n.c.  |

Tab. 25: Pin assignment – connection X841

#### 8-pin connector with push-in connection

| Parameter  | Description                                   |
|--|---|
| Connection technique   | Spring connection, push-in                    |
| Type   | 8-pin, 3.5 mm pitch                           |
| Conductor cross-section, multi-wire                                      | 0.2 mm <sup>2</sup> ... 1.5 mm <sup>2</sup>   |
| Stripping length   | 9 mm ... 10 mm                                |
| Conductor cross-section, multi-wire with wire end ferrule with sleeve    | 0.25 mm <sup>2</sup> ... 0.75 mm <sup>2</sup> |
| Conductor cross-section, multi-wire with wire end ferrule without sleeve | 0.25 mm <sup>2</sup> ... 1.5 mm <sup>2</sup>  |
| Contact length   | 8 mm ... 10 mm                                |

Tab. 26: Connector specification, 8 pins, push-in connection

### 6.3.7 Connection X843 – Extended safety function [S2]

There is a modified, extended signal assignment for the optional extended safety function FSoE -S2 that deviates from the built-in default STO function. The X843 connection is present on -S2 devices only.

Safe resolvers and safe HIPERFACE DSL® are the only possible safe encoder interfaces. The motors must be equipped with safe encoders.

Programming the digital I/Os and extended safety functions in the FSoE slave mandates a safety programming software and the use of a safety controller (e.g. JSC) as FSoE master to complement the motion control.

## NOTICE



### Applicable documents

Please observe the information given in the *Integrated Safety Function S2 Functional Description* for further details.

### Pin assignment

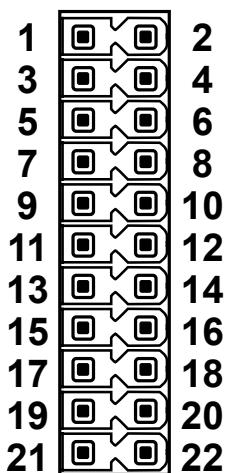

Fig. 24: Connection X843

| Pin | Signal            | Description          |
|-----|-------------------|----------------------|
| 1   | DI1-A             | Digital input 1-A    |
| 2   | DI1-B             | Digital input 1-B    |
| 3   | DI2-A             | Digital input 2-A    |
| 4   | Digital Input 2-B | Digital input 2-B    |
| 5   | DI3-A             | Digital input 3-A    |
| 6   | DI3-B             | Digital input 3-B    |
| 7   | DI4-A             | Digital input 4-A    |
| 8   | DI4-B             | Digital input 4-B    |
| 9   | Error ACK         | Error acknowledgment |
| 10  | Restart ACK       | Restart confirmation |
| 11  | GND               |                      |
| 12  | GND               |                      |
| 13  | DO1-A             | Digital output 1-A   |
| 14  | DO1-B             | Digital output 1-B   |
| 15  | DO2-A             | Digital output 2-A   |
| 16  | DO2-B             | Digital output 2-B   |
| 17  | GND               |                      |
| 18  | GND               |                      |
| 19  | Status of SBC     | State of SBC         |
| 20  | n.c.              |                      |

| Pin | Signal                          | Description                                  |
|-----|---------------------------------|--|
| 21  | DC 24 V<br>(U <sub>OSSD</sub> ) | OSSD supply (Output Signal Switching Device) |
| 22  | DC 24 V<br>(U <sub>OSSD</sub> ) | OSSD supply (Output Signal Switching Device) |

**22-pin connector with push-in connection**

| Parameter  | Description                                   |
|--|---|
| Connection technique   | Spring connection, push-in                    |
| Type   | 22-pin, 3.5 mm pitch                          |
| Conductor cross-section, multi-wire                                      | 0.2 mm <sup>2</sup> ... 1.5 mm <sup>2</sup>   |
| Stripping length   | 9 mm ... 10 mm                                |
| Conductor cross-section, multi-wire with wire end ferrule with sleeve    | 0.25 mm <sup>2</sup> ... 0.75 mm <sup>2</sup> |
| Conductor cross-section, multi-wire with wire end ferrule without sleeve | 0.25 mm <sup>2</sup> ... 1.5 mm <sup>2</sup>  |
| Contact length   | 8 mm ... 10 mm                                |

**Tab. 27:** Connector specification, 22 pins, push-in connection

### 6.3.8 Connection X210 – digital inputs

– 4 digital inputs

#### Pin assignment

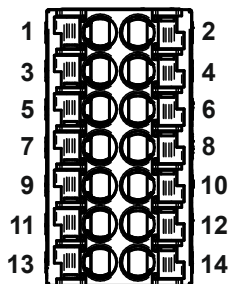

Fig. 25: Terminal X210, 14 pins

|            | Pin       |          | Axis 1     | Description              |
|------------|-----------|----------|------------|--------------------------|
| <b>TP2</b> | <b>1</b>  | <b>2</b> | <b>TP1</b> | TouchProbe               |
| n.c.       | 3         | 4        | <b>L+</b>  | Limit switch + (limit +) |
| n.c.       | 5         | 6        | <b>L-</b>  | Limit switch – (limit -) |
| n.c.       | 7         | 8        | <b>R</b>   | Reference signal         |
| n.c.       | 9         | 10       | n.c.       |                          |
| <b>GND</b> | <b>11</b> | 12       | n.c.       |                          |
| n.c.       | 13        | 14       | n.c.       |                          |

Tab. 28: Pin assignment – connection X210

#### 14-pin connector with push-in connection

| Parameter  | Description                                   |
|--|---|
| Connection technique   | Spring connection, push-in                    |
| Type   | 14-pin, 3.5 mm pitch                          |
| Conductor cross-section, multi-wire                                      | 0.2 mm <sup>2</sup> ... 1.5 mm <sup>2</sup>   |
| Stripping length   | 9 mm ... 10 mm                                |
| Conductor cross-section, multi-wire with wire end ferrule with sleeve    | 0.25 mm <sup>2</sup> ... 0.75 mm <sup>2</sup> |
| Conductor cross-section, multi-wire with wire end ferrule without sleeve | 0.25 mm <sup>2</sup> ... 1.5 mm <sup>2</sup>  |
| Contact length   | 8 mm ... 10 mm                                |

Tab. 29: Connector specification, 14 pins, push-in connection

### 6.3.9 Braking resistors [-R]

An internal braking resistor is installed in the JM-2203 / JM-2403 device (ID **-R1** in the order code).

#### Connection

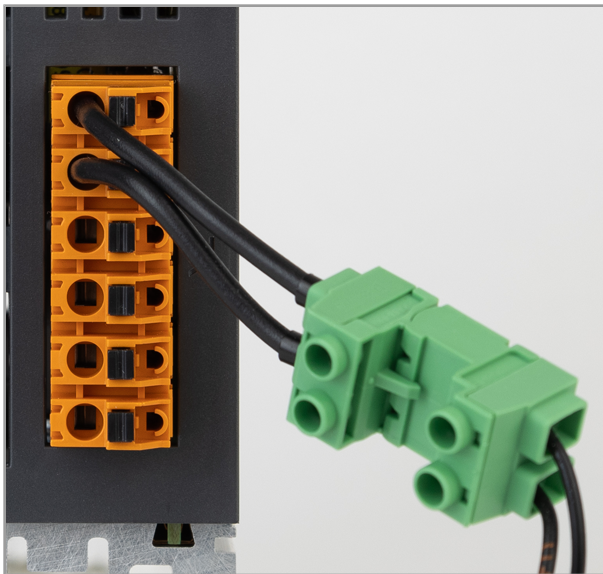

Fig. 26: 2-pin adapter plug to X2

The internal or optional external braking resistor is connected via a 2-pin adapter plug with terminals **RB1** and **RB2** of connector terminal **X2**.

If you would like to use an external braking resistor, disconnect the 2 wires from connector terminal X2. Connect the external braking resistor to **RB1** and **RB2**. The 2-pin adapter plug no longer has any function, but can be left on the device in the control cabinet.

#### 2-pin adapter plug, socket (female)

| Parameter  | Description                                  |
|--|--|
| Connection technique   | Screw connection with puller sleeve          |
| Type   | 2-pin, 7.62 mm pitch                         |
| Nominal cross section  | 2.5 mm <sup>2</sup>                          |
| Conductor cross-section single-wire                                      | 0.2 mm <sup>2</sup> ... 2.5 mm <sup>2</sup>  |
| Conductor cross-section, multi-wire                                      | 0.2 mm <sup>2</sup> ... 2.5 mm <sup>2</sup>  |
| Stripping length   | 8 mm   |
| Conductor cross-section, multi-wire with wire end ferrule without sleeve | 0.25 mm <sup>2</sup> ... 2.5 mm <sup>2</sup> |
| Conductor cross-section, multi-wire with wire end ferrule with sleeve    | 0.25 mm <sup>2</sup> ... 2.5 mm <sup>2</sup> |
| Conductor with same cross-section, single-wire                           | 0.2 mm <sup>2</sup> ... 1 mm <sup>2</sup>    |
| 2 conductors with same cross-section, multi-wire                         | 0.2 mm <sup>2</sup> ... 1.5 mm <sup>2</sup>  |

| Parameter  | Description                                |
|--|--|
| 2 conductors with same cross-section, multi-wire end ferrule without sleeve            | 0.25 mm <sup>2</sup> ... 1 mm <sup>2</sup> |
| 2 conductors with same cross-section, multi-wire with TWIN wire end ferrule and sleeve | 0.5 mm <sup>2</sup> ... 1 mm <sup>2</sup>  |
| Plug gauge a x b / diameter  | 2.8 mm x 2.4 mm / 2.5 mm                   |
| Tightening torque  | 0.5 Nm ... 0.6 Nm                          |

**Tab. 30:** Connector specification, 2-pin, adapter plug

### 2-pin adapter plug, pins (male)

| Parameter  | Description                                  |
|--|--|
| Connection technique   | Screw connection with puller sleeve          |
| Type   | 2-pin, 7.62 mm pitch                         |
| Nominal cross section  | 2.5 mm <sup>2</sup>                          |
| Conductor cross-section single-wire  | 0.2 mm <sup>2</sup> ... 2.5 mm <sup>2</sup>  |
| Conductor cross-section, multi-wire  | 0.2 mm <sup>2</sup> ... 2.5 mm <sup>2</sup>  |
| Stripping length   | 8 mm   |
| Conductor cross-section, multi-wire with wire end ferrule without sleeve               | 0.25 mm <sup>2</sup> ... 2.5 mm <sup>2</sup> |
| Conductor cross-section, multi-wire with wire end ferrule with sleeve                  | 0.25 mm <sup>2</sup> ... 2.5 mm <sup>2</sup> |
| Conductor with same cross-section, single-wire   | 0.2 mm <sup>2</sup> ... 1 mm <sup>2</sup>    |
| 2 conductors with same cross-section, multi-wire                                       | 0.2 mm <sup>2</sup> ... 1.5 mm <sup>2</sup>  |
| 2 conductors with same cross-section, multi-wire end ferrule without sleeve            | 0.25 mm <sup>2</sup> ... 1 mm <sup>2</sup>   |
| 2 conductors with same cross-section, multi-wire with TWIN wire end ferrule and sleeve | 0.5 mm <sup>2</sup> ... 1 mm <sup>2</sup>    |
| Plug gauge a x b / diameter  | 2.8 mm x 2.0 mm / 2.4 mm                     |
| Tightening torque  | 0.5 Nm ... 0.6 Nm                            |

**Tab. 31:** Connector specification, 2-pin, adapter plug

## 6.4 Encoder plug-in slots

The JM-2203 / JM-2403 has 2 encoder plug-in slots.

The order of the encoders on the JM-2203 / JM-2403 is always from right to left.

For the encoder assembly, refer to the [nameplate \[▶ 20\]](#) and the order code.



**Fig. 27:** Encoder plug-in slots

|   |  |
|---|--|
| 1 | Connection X412 - motor encoder for axis 1 |
| 2 | Additional encoder                         |

### 6.4.1 Encoder option -R / -S2R – resolver

Encoder option –R is designed to connect to a resolver. Encoder option –S2R is designed to connect to a safe resolver.

#### Fields of application

Encoder option – R can be used as:

- Motor encoder for axis 1 to X412

Encoder option –S2R can be used as:

- Motor encoder for axis 1 to X412

#### Pin assignment

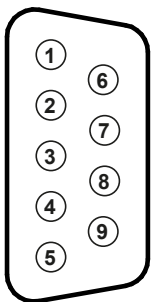

Fig. 28: Sub-D, 9-pin, socket

| Pin | Signal     | Description                             |
|-----|------------|---|
| 1   | R1 (Err +) | Excitation winding +                    |
| 2   | S4 (Sin -) | Resolver winding A -                    |
| 3   | S3 (Cos -) | Resolver winding B +                    |
| 4   | Th1 -      | Terminal for motor temperature sensor - |
| 6   | R2 (Err -) | Excitation winding -                    |
| 7   | S2 (Sin +) | Resolver winding A+                     |
| 8   | S1 (Cos +) | Resolver winding B -                    |
| 9   | Th1 +      | Terminal for motor temperature sensor + |

#### Ready-made cable

You can order suitable ready-made KAY\_1423\_xxxx cables separately as [accessories](#) [▶ 68]. Due to the installation space constraints in the control cabinet, we recommend using the Bucher Automation cable with angled Sub-D housing.

| For example, 12-pin M23 socket on the Bucher Automation motor | Resolver   | Cables | Sub-D, 9-pin, plug to KAY_1423_xxxx |
|---|------------|--------|-------------------------------------|
| Pin   | Signal     | Color  | Pin                                 |
| 1   | S1 (Cos +) | RD     | 8                                   |
| 2   | S3 (Cos -) | BU     | 3                                   |
| 3   | S4 (Sin -) | YE     | 2                                   |
| 4   | S2 (Sin +) | GN     | 7                                   |
| 5   | R1 (Err +) | PK     | 1                                   |
| 6   | R2 (Err -) | GY     | 6                                   |
| 7   | Th1 +      | WH     | 9                                   |
| 8   | Th1 -      | BN     | 4                                   |

Colors    and    indicate twisted wires in the encoder cables with encoder shield.

### 6.4.2 Encoder options –H – HIPERFACE DSL®

Encoder option –H is designed to connect to a HIPERFACE-DSL® encoder with 2-wire design (1-cable system). The encoder module can supply an encoder with a maximum of 1 W.

#### Fields of application

Encoder option –H can be used as:

- Motor encoder for axis 1 to X412

#### Pin assignment

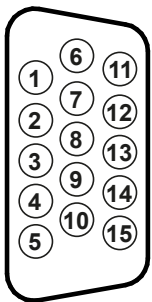

| Pin | Signal |
|-----|--------|
| 9   | DSL-   |
| 14  | DSL+   |

Fig. 29: Sub-D, 15-pin, socket

#### Ready-made cable

You can order the suitable ready-made KAY\_1411\_xxxx and KAY\_1413\_xxxx cables separately as **accessories** ▶ 68]. Due to the installation space constraints in the control cabinet, we recommend using the Bucher Automation cable with angled Sub-D housing.

This cable is a hybrid cable. The wiring leads to 3 different connectors on the JM-2203 / JM-2403. The pin names differ depending on the servo motor being used. For details, refer to the user manual of the respective servo motor available on [www.bucherautomation.com](http://www.bucherautomation.com).

| E.g. socket on Bucher Automation motor (M23) | HIPERFACE-DSL® encoder | Cables           | Sub-HD, 15-pin, plug to KAY_1411_xxxx KAY_1413_xxxx | Connection to the JM-2000 (not number of axes) |
|--|------------------------|------------------|---|--|
| Pin  | Signal                 | Wire no. / color | Pin   | Motor connection                               |
| A  | Phase 1                | 1                |   | X2/X3  |
| B  | Phase 2                | 2                |   |  |
| C  | Phase 3                | 3                |   |  |
| D  | Protective conductor   | GN-YE            |   |  |
|  |                        |                  |   | <b>Brake</b>                                   |
| G  | Brake+                 | 6                |   | X21/X22  |
| F  | Brake-                 | 5                |   |  |

| E.g. socket on Bucher Automation motor (M23) | HIPERFACE-DSL® encoder | Cables | Sub-HD, 15-pin, plug to KAY_1411_xxxx<br>KAY_1413_xxxx | Connection to the JM-2000 (not number of axes) |
|--|------------------------|--------|--|--|
|  |                        |        |  | <b>Encoder connection</b>                      |
| E  | DSL+                   | WH     | <b>14</b>  | X412/X422                                      |
| H  | DSL-                   | BU     | <b>9</b>   |  |
| L  | DSL shield             |        |  |  |

The color    indicates twisted pair wires in the encoder cables with encoder shield.

### 6.4.3 Encoder option –A – External SinCos encoder

Encoder option –A makes it possible to connect an external SinCos encoder (2-cable system).

#### Fields of application

Encoder option –A can be used as:

- Motor encoder for axis 1 to X412
- Additional encoder on X432

#### Pin assignment

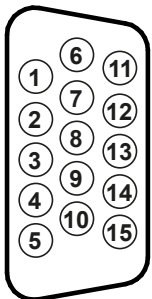

**Fig. 30:** Sub-D, 15-pin, socket

| Pin | Description                             |
|-----|---|
| 3   | Reference cosine                        |
| 4   | Cosine+                                 |
| 5   | Terminal for motor temperature sensor - |
| 6   | Voltage supply (DC 12 V max)            |
| 7   | Reference pulse -                       |
| 9   | Reference sine                          |
| 10  | Terminal for motor temperature sensor + |
| 11  | V_Sense                                 |
| 12  | Reference pulse +                       |
| 14  | Sine+                                   |
| 15  | Ground (GND)                            |

### 6.4.4 Encoder option –A – HIPERFACE® analog

Encoder option –A is designed to connect to a HIPERFACE encoder (2-cable system).

#### Fields of application

Encoder option –A can be used as:

- Motor encoder for axis 1 to X412
- Additional encoder on X432

#### Pin assignment

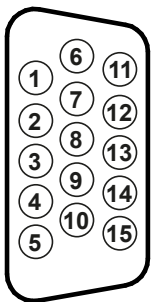

Fig. 31: Sub-D, 15-pin, socket

| Pin | Description                             |
|-----|---|
| 3   | Reference cosine                        |
| 4   | Cosine+                                 |
| 5   | Terminal for motor temperature sensor - |
| 6   | Voltage supply (DC 7 V ... DC 12 V)     |
| 8   | DATA - (RS-485)                         |
| 9   | Reference sine                          |
| 10  | Terminal for motor temperature sensor + |
| 11  | V_Sense                                 |
| 13  | DATA + (RS-485)                         |
| 14  | Sine +                                  |
| 15  | Ground (GND)                            |

#### Ready-made cable

You can order suitable ready-made KAY\_1433\_xxxx cables separately as [accessories](#) [▶ 68]. Due to the installation space constraints in the control cabinet, we recommend using the Bucher Automation cable with angled Sub-D housing.

| 12-pin socket | HIPERFACE® encoder | Cables     | HD-Sub-D, 15-pin, plug o KAY_1433_xxxx |
|---------------|--------------------|------------|--|
| Pin           | Signal             | Wire color | Pin                                    |
| 1             | -                  | -          | -                                      |
| 2             | -                  | -          | -                                      |
| 3             | Sin +              | WH         | 14                                     |
| 4             | Sin -              | BN         | 9                                      |
| 5             | Cos +              | GN         | 4                                      |
| 6             | Cos -              | YE         | 3                                      |
| 7             | Data - (RS-485)    | GY         | 8                                      |
| 8             | Data + (RS-485)    | PK         | 13                                     |

| 12-pin socket | HIPERFACE® encoder | Cables | HD-Sub-D, 15-pin, plug o<br>KAY_1433_xxxx |
|---------------|--------------------|--------|---|
| 9             | 0 V                | BU     | 15  |
| 10            | Vers. 7 ... 12 V   | RD     | 6   |
| 11            | Th1 +              | BK     | 10  |
| 12            | Th1 -              | VT     | 5   |
|               |                    |        | 11  |

Colors  and  indicate twisted wires in the encoder cables with encoder shield.

### 6.4.5 Encoder option –I – incremental encoder

Encoder option –I makes it possible to connect an incremental encoder (2-cable system).

#### Fields of application

Encoder option –I can be used as:

- Additional encoder on X432

#### Pin assignment

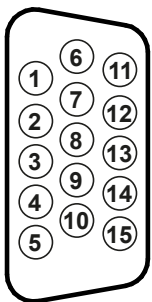

Fig. 32: Sub-D, 15-pin, socket

| Pin | Signal                  | Description                                 |
|-----|-------------------------|---|
| 3   | B_IN - (B -)            | Input channel B -                           |
| 4   | B_IN + (B +)            | Input channel B +                           |
| 5   | TM - (T -)              | Input thermistor Th1 -                      |
| 6   | V_ABS<br>(max. DC 12 V) | Output DC 5 V supply of external encoders   |
| 7   | R_IN - (C -)            | Input zero pulse -                          |
| 9   | A_IN - (A -)            | Input channel A -                           |
| 10  | TM + (T +)              | Input thermistor Th1 +                      |
| 11  | V_Sense                 | Input for voltage correction via sense line |
| 12  | R_IN + (C +)            | Input zero pulse +                          |
| 14  | A_IN + (A +)            | Input channel A +                           |
| 15  | GND                     | Output DC 0 V supply of external encoders   |

### 6.4.6 Encoder option –E6 – EnDat® 2.2

Encoder option –E6 is designed to connect to an EnDat® 2.2 encoder (2-cable system).

#### Fields of application

Encoder option –E6 can be used as:

- Motor encoder for axis 1 to X412
- Additional encoder on X432

#### Pin assignment

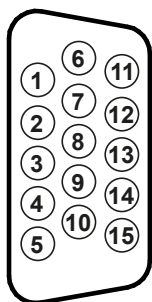

Fig. 33: Sub-D, 15-pin, socket

| Pin | Signal                 | Description                                   |
|-----|------------------------|---|
| 1   | Clock -                | Endat® 2.2 signal                             |
| 2   | Clock +                | Endat® 2.2 signal                             |
| 6   | V_ABS<br>(DC 12 V max) | DC 5 V supply voltage for an external encoder |
| 8   | Data -                 | Endat® 2.2 signal                             |
| 13  | Data +                 | Endat® 2.2 signal                             |
| 15  | (GND)                  | DC 0 V supply voltage for an external encoder |

#### Ready-made cable

You can order suitable ready-made KAY\_1431\_xxxx cables separately as [accessories](#) [▶ 68]. Due to the installation space constraints in the control cabinet, we recommend using the Bucher Automation cable with angled Sub-D housing.

| 12-pin socket | EnDat® 2.2 encoder | Cables     | HD-Sub-D, 15-pin, plug o<br>KAY_1433_xxxx |
|---------------|--------------------|------------|---|
| Pin           | Signal             | Wire color | Pin                                       |
| 1             | Th1 +              | GN         | 10  |
| 2             | Th1 -              | YE         | 5   |
| 3             | Data -             | WH         | 8   |
| 4             | Data +             | BN         | 13  |
| 5             | -                  |            |   |
| 6             | -                  |            |   |
| 7             | Clock -            | GY         | 1   |
| 8             | Clock +            | PK         | 2   |
| 9             | 0 V                | BU         | 15  |
| 10            | DC 5 V             | RD         | 6   |
| 11            | -                  |            |   |
| 12            | -                  |            |   |

Colors and indicate twisted wires in the encoder cables with encoder shield.

# 7 Maintenance

This product is maintenance-free. The operation of the product does not require inspection or maintenance efforts.

## 7.1 Repairs

Defective components can cause dangerous malfunctions and compromise safety.

Only the manufacturer is authorized to perform repair work.

It is forbidden to open the product.

### Product modifications

Modifications and alterations to the product and its functions are not allowed. The manufacturer exempts from liability for any modifications made to the product.

The original parts are specifically designed for the product. Parts and equipment from other manufacturers must not be used.

The manufacturer exempts from liability for any damage resulting from the use of non-original parts and equipment is excluded.

## 7.2 Storage and Shipment

### Storage

When storing the product, observe the environmental conditions given in chapter "Technical specifications".

### Shipment and packaging

The product contains electrostatically sensitive components which can be damaged if not handled properly. Damages to the product can impair its reliability.

To protect the product from impact or shock, it must be shipped in its original packaging, or in an appropriate protective ESD packaging.

If the packaging is damaged, inspect the device for any visible damage, and immediately inform your freight forwarder and Bucher Automation AG of the damage caused during shipment. It is strictly forbidden to use a product that has been damaged or dropped.

## 7.3 Return and Disposal

The WEEE icon (crossed-out wheeled bin) says that end users must not dispose of waste electrical and electronic equipment together with household waste, but separately in an appropriate way. Applicable local environmental directives and regulations must be complied with.

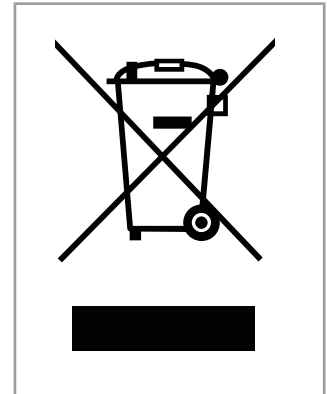

**Fig. 34:** WEEE icon – crossed out wheeled bin

### Disposal options

To do so, you may either resort to professional disposal service providers or return waste electronics to Bucher Automation AG.

Find detailed information along with the required Return Delivery Form on our [website](#).

### Batteries

Prior to disposing of waste electronics, remove any batteries where this is possible in a safe and non-destructive way. Dispose of batteries properly.

### Personal data

It is the responsibility of the end user to delete any personal data stored on waste electric and electronic equipment prior to disposal.

### Packaging material

The product's packaging materials must not be disposed of together with household waste. Find detailed information on how to return packaging material to Bucher Automation AG on our [website](#).

# 8 Service

## 8.1 Technical Support

If you have any questions, suggestions, or issues, our technical support team is here to assist you with their expertise. You can reach them by phone or through the contact form on our website:

[Technical Support | www.bucherautomation.com](http://www.bucherautomation.com)

Or send us an email:

[support@bucherautomation.com](mailto:support@bucherautomation.com)

Technical Support needs the following information:

- Hardware Revision and Serial Number  
You can find the serial number and hardware revision of your product on the nameplate.
- Operating system version  
You can determine the operating system version using the development environment.

## 9 Spare parts and accessories

### NOTICE



#### Inadequate accessories might cause damage to the product

Parts and equipment from other manufacturers might impede the function of the device and cause damage to the product.

- ▶ Only use accessories recommended by Bucher Automation AG.

### 9.1 Spare parts

| Component                             | Item number |
|---------------------------------------|-------------|
| USB stick with complete documentation | 60888000    |

#### 9.1.1 Mounting hardware

| Component  | Item number |
|--|-------------|
| Top fitting panel  | 60885886    |
| Bottom fitting panel                                     | 60885603    |
| Fastening bracket for motor cable with shielding bracket | 60886090    |

#### 9.1.2 Front covers

| Component                                     | Item number |
|---|-------------|
| Upper front cover with Bucher Automation logo | 60885604    |
| Bottom front cover, frame size 1              | 60886060    |

#### 9.1.3 Connector sets

| Component   | Item number |
|---|-------------|
| Brake resistor connector set                                  | 60887619    |
| I/O and S1 connector set, single-axis                         | 60886077    |
| I/O and S2 connector set, single-axis                         | 60886078    |
| Power-level terminal connector set, single-axis, frame size 1 | 60886080    |

Tab. 32: Spare parts – connector sets

## 9.2 Accessories

### 9.2.1 Pre-assembled cables

#### Encoder cables

| Component   | Cable assembly |
|---|----------------|
| <b>KAY_1423_XXXX</b><br>resolver cable  | (4 x 2 x 0.25) |
| <b>KAY_1423Y_XXXX</b><br>Resolver cable for motor with Y-Tec connector (12-pin operation)               | (4 x 2 x 0.25) |
| <b>KAY_1424_XXXX</b><br>SinCos cable  | (5 x 2 x 0.25) |
| <b>KAY_1425_XXXX</b><br>Incremental encoder cable with 17-pin operation Intercontec for JHQ motor (F41) | (5 x 2 x 0.25) |
| <b>KAY_1425A_XXXX</b><br>Incremental encoder cable with 12-pin operation Intercontec                    | (5 x 2 x 0.25) |
| <b>KAY_1431_XXXX</b><br>EnDat 2.2 cable, 6 wires  | (4 x 2 x 0.25) |
| <b>KAY_1433_XXXX</b><br>HIPERFACE® cable  | (5 x 2 x 0.25) |
| <b>KAY_1433Y_XXXX</b><br>HIPERFACE®-cable for motor with Y-Tec connector (12-pin operation)             | (5 x 2 x 0.25) |

#### Power cables

| Component   | Cable assembly        |
|---|-----------------------|
| <b>KAY_1410_XXXX</b><br>1.5 mm <sup>2</sup> power cable without brake (2-cable system)                                  | (4 x 1.5)             |
| <b>KAY_1410Y_XXXX</b><br>1.5 mm <sup>2</sup> power cable without brake (2-cable system), for motor with Y-Tec connector | (4 x 1.5)             |
| <b>KAY_1412_XXXX</b><br>1.5 mm <sup>2</sup> power cable with brake (2-cable system)                                     | (4 x 1.5 + (2 x 1.5)) |
| <b>KAY_1412Y_XXXX</b><br>1.0 mm <sup>2</sup> power cable with brake (2-cable system), for motor with Y-Tec connector    | (4 x 1.0 + (2 x 0.5)) |
| <b>KAY_1414_XXXX</b><br>power cable (2-cable system)  | (4 x 2.5 + (2 x 1.5)) |

**HIPERFACE® DSL cable (always with brake wires)**

| Component  | Cable assembly                          |
|--|---|
| <b>KAY_1411_xxxx</b><br>1.0 mm <sup>2</sup> HIPERFACE® DSL (1-cable system)<br>for motor with M23 connector    | (4 x 1.0 + (2 x 0.75) +<br>(2 x AWG22)) |
| <b>KAY_1411I_xxxx</b><br>1.0 mm <sup>2</sup> HIPERFACE® DSL (1-cable system)<br>for motor with I-Tec connector | (4 x 1.0 + (2 x 0.75) +<br>(2 x AWG22)) |
| <b>KAY_1413_xxxx</b><br>1.5 mm <sup>2</sup> HIPERFACE® DSL (1-cable system)<br>for motor with M23 connector    | (4 x 1.5 + (2 x 0.75) +<br>(2 x AWG22)) |
| <b>KAY_1415_xxxx</b><br>2.5 mm <sup>2</sup> HIPERFACE® DSL (1-cable system)<br>for motor with M23 connector    | (4 x 2.5 + (2 x 0.75) +<br>(2 x AWG22)) |

**9.2.2 EtherCAT® cable**

| Component   | Item number |
|---|-------------|
| Patch cable 1:1, 0.25 m, gray, Hirose, Cat 5e, shielded | 60887736    |
| Patch cable 1:1, 1 m, gray, Hirose, Cat 5e, shielded    | 60537500    |
| Patch cable 1:1, 2 m, gray, Hirose, Cat 5e, shielded    | 60854512    |

**9.2.3 External line filter**

| Type          | Item number |
|---------------|-------------|
| JEMC25.240-UR | 60880639    |
| JEMC53.240-UR | 60880640    |

**9.2.4 Optional external brake resistors****For JM-2203**

| Type             | External | Rated power | Peak power | Item number |
|------------------|----------|-------------|------------|-------------|
| JBR090.02.540-UR | 90 Ω     | 200 W       | 6,250 W    | 60880282    |
| JBR090.03.540-UR |          | 300 W       | 6,250 W    | 60880283    |

**For JM-2403**

| Type             | External | Rated power | Peak power | Item number |
|------------------|----------|-------------|------------|-------------|
| JBR200.02.540-UR | 200 Ω    | 200 W       | 2,813 W    | 60880287    |

## List of figures

|         |  |    |
|---------|--|----|
| Fig. 1  | Safety label.....  | 13 |
| Fig. 2  | Safety Label: Discharge Time .....                             | 14 |
| Fig. 3  | Design .....   | 15 |
| Fig. 4  | Status indication .....  | 16 |
| Fig. 5  | Main Nameplate .....   | 20 |
| Fig. 6  | Example of placement -S2 .....                                 | 22 |
| Fig. 7  | Dimension in mm.....   | 25 |
| Fig. 8  | Derating diagrams .....  | 31 |
| Fig. 9  | Distances from surrounding parts in mm.....                    | 34 |
| Fig. 10 | Dimensions ext. line filter.....                               | 36 |
| Fig. 11 | Mounting the shield connecting bracket on the line filter..... | 37 |
| Fig. 12 | Protective earth conductor terminal.....                       | 40 |
| Fig. 13 | Connection at the PE connector.....                            | 41 |
| Fig. 14 | EMC-compliant Sub-D shield connection .....                    | 41 |
| Fig. 15 | Connection instructions .....                                  | 43 |
| Fig. 16 | Connection overview top and bottom .....                       | 44 |
| Fig. 17 | Connection overview front.....                                 | 45 |
| Fig. 18 | Socket X212 .....  | 46 |
| Fig. 19 | Terminal X1,<br>6 pins .....                                   | 47 |
| Fig. 20 | Terminal X2,<br>6 pins .....                                   | 48 |
| Fig. 21 | Terminal X12,<br>4 pins .....                                  | 49 |
| Fig. 22 | Terminal X21,<br>2 pins .....                                  | 50 |
| Fig. 23 | Terminal X841, 8 pins.....                                     | 51 |
| Fig. 24 | Connection X843.....   | 52 |
| Fig. 25 | Terminal X210, 14 pins.....                                    | 54 |
| Fig. 26 | 2-pin adapter plug to X2 .....                                 | 55 |
| Fig. 27 | Encoder plug-in slots .....                                    | 57 |
| Fig. 28 | Sub-D, 9-pin, socket.....                                      | 58 |
| Fig. 29 | Sub-D, 15-pin, socket.....                                     | 59 |
| Fig. 30 | Sub-D, 15-pin, socket .....                                    | 60 |
| Fig. 31 | Sub-D, 15-pin, socket.....                                     | 61 |
| Fig. 32 | Sub-D, 15-pin, socket.....                                     | 62 |
| Fig. 33 | Sub-D, 15-pin, socket.....                                     | 63 |
| Fig. 34 | WEEE icon – crossed out wheeled bin.....                       | 65 |

## List of tables

|         |  |    |
|---------|--|----|
| Tab. 1  | Technical data – mechanical properties .....                       | 26 |
| Tab. 2  | Technical Specifications – Motor-Side Output.....                  | 26 |
| Tab. 3  | External braking resistor.....                                     | 26 |
| Tab. 4  | Technical data – mains-side input.....                             | 27 |
| Tab. 5  | Eaton Individual circuit breakers.....                             | 27 |
| Tab. 6  | Technical data – DC 24 V voltage supply.....                       | 28 |
| Tab. 7  | Technical data – activation of motor holding brake .....           | 28 |
| Tab. 8  | Technical data – digital inputs .....                              | 28 |
| Tab. 9  | Technical data – EtherCAT® interface.....                          | 29 |
| Tab. 10 | Technical data - Environmental conditions.....                     | 29 |
| Tab. 11 | Technical data – external line filter .....                        | 30 |
| Tab. 12 | Output current derating depending on the switching frequency ..... | 30 |
| Tab. 13 | Dimensions – external line filter.....                             | 36 |
| Tab. 14 | Suitable line filters .....  | 42 |
| Tab. 15 | LEDs – EtherCAT® RJ45 socket.....                                  | 46 |
| Tab. 16 | LEDs – EtherCAT® status.....                                       | 46 |
| Tab. 17 | Pin assignment – terminal X1.....                                  | 47 |
| Tab. 18 | Connector specification, 6 pins, push-in connection .....          | 47 |
| Tab. 19 | Pin assignment- connection X2.....                                 | 48 |
| Tab. 20 | Connector specification, 6 pins, push-in connection .....          | 48 |
| Tab. 21 | Pin assignment – connection X12 .....                              | 49 |
| Tab. 22 | Connector specification, 4 pins, push-in connection .....          | 49 |
| Tab. 23 | Pin assignment – connection X21 .....                              | 50 |
| Tab. 24 | Connector specification, 2 pins, push-in connection .....          | 50 |
| Tab. 25 | Pin assignment – connection X841 .....                             | 51 |
| Tab. 26 | Connector specification, 8 pins, push-in connection .....          | 51 |
| Tab. 27 | Connector specification, 22 pins, push-in connection .....         | 53 |
| Tab. 28 | Pin assignment – connection X210 .....                             | 54 |
| Tab. 29 | Connector specification, 14 pins, push-in connection .....         | 54 |
| Tab. 30 | Connector specification, 2-pin, adapter plug .....                 | 55 |
| Tab. 31 | Connector specification, 2-pin, adapter plug .....                 | 56 |
| Tab. 32 | Spare parts – connector sets.....                                  | 67 |

---

**Bucher Automation AG**

Thomas-Alva-Edison-Ring 10  
71672 Marbach/Neckar, Germany  
T +49 7141 2550-0  
[info@bucherautomation.com](mailto:info@bucherautomation.com)



[www.bucherautomation.com](http://www.bucherautomation.com)